



DDX - 60SD

60 CHANNEL DIGITAL DEMULTIPLEXER

FOR DIGITAL TO ANALOGUE LIGHTING CONTROL CONVERSION

OPERATOR'S MANUAL

MANUFACTURED IN AUSTRALIA FOR INTERNATIONAL CONDITIONS BY:

JANDS ELECTRONICS P/L
578 PRINCES H'WAY
ST PETERS NSW 2033
AUSTRALIA

PHONE: + 61-2-5163622

FAX: + 61-2-5171045

Table of Contents

	Page
Table of Contents	i
List of Figures	ii
1. Introduction	1-1
1.1 Features.....	1-1
2. Description.....	2-1
2.1 Physical layout.....	2-2
3. Powering up.....	3-1
3.1 To select a bank.....	3-1
3.2 Final test.....	3-1
3.3 Normal operation.....	3-2
3.4 `Snapshot' backup operation	3-2
3.5 Test modes	3-3
3.6 Interruptions	3-3
4. Fault diagnosis	4-1
5. Installation	5-1
5.1 Mains supply.....	5-1
5.2 Output voltage adjustment	5-1
5.3 Rack mounting	5-1
5.4 Wiring	5-1
6. Maintenance Instructions	6-1
6.1 Cleaning	6-1
6.2 Guarantee	6-1
7. Specifications	7-1
7.1 Spare parts and accessories.....	7-2
7.2 Connector pin terminations.....	7-3

List of Figures

	Page
Figure 2.1 DDX-60SD FRONT AND BACK PANEL LAYOUT.....	2-3
Figure 5.1 OUTPUT VOLTAGE ADJUSTMENT.....	5-1

1. Introduction

The JANDS DDX-60SD is a professional digital receiver/line-driver designed for use in digital multiplex control systems. The DDX-60SD bridges the gap between existing technology wire-per-channel analogue receivers and the more recently introduced digital control desks. The use of digital multiplexing allows up to 512 control channels to be transmitted through a single shielded-pair cable, saving on both cost and weight over a standard analogue system.

1.1 Features

Advanced software features make DDX-60SD very operator-friendly.

- Low-battery display notifies operator when internal battery needs replacing.
- In-built Test software aids system testing and lamp focusing.
- Output hold facility retains the output levels present immediately prior to disconnection of the digital data cable.
- Internal memory stores channel setting and backup Snapshot facilities.

Accepts DMX-512 protocol.

- This is the digital multiplex system specified by the USITT.
- Using this protocol allows the DDX-60SD to be used with a variety of existing and future equipment without the need for costly interfaces and converters.

Allows existing analogue systems to be upgraded to digital control simply and effectively without having to invest in a complete digital system.

Control Line Output Drive.

- To optimise the data transmission each DDX-60SD operates as a repeater for the DMX-512 control line, re-transmitting the data instead of simply receiving only.
- In the event of a power failure, the control line is automatically switched through, maintaining signal to other receiving units.

Receives full speed 250k baud data transmission rate.

Full 8 bit conversion giving smooth unstepped response.

60 output channels for direct connection to analogue dimmer control inputs.

All analogue outputs are short circuit protected.

Outputs on 8-pin DIN connectors or 37-pin Socapex connectors (optional) to suit both temporary or permanent installations.

Industry standard input/link connector (5-pin XLR).

Reduced cable costs, size and weight.

90 - 260 Volt universal mains operation.

Two year warranty (Australia only).

Steel 19" two rack-unit chassis.

2. Description

The DDX-60SD decodes signals which conform to USITT DMX-512 specification, and converts them to their analogue equivalent. This specification allows for up to 512 control channels to be sent via a balanced digital line. Each DDX-60SD decodes a bank of 60 channels as selected by the switches on the front panel. Where more than one DDX-60SD is used in a system, the digital line is 'daisy-chained' using the "DMX OUT" connector on the front panel. Each DDX-60SD on this line will terminate the line and re-transmit the control information automatically, resulting in optimum signal transmission under poor conditions.

The 60 analogue outputs are directly compatible with most existing wire-per-channel receivers, such as dimmers and colour scrollers, being 0 to +10 Volts DC. The outputs are terminated on ten 8-pin DIN connectors (or two optional 37-pin Socapex connectors) on the back panel, suiting both temporary and permanent applications.

Each unit comes ready to mount in a standard 19" rack and occupies 2 rack spaces (3¹/₂ inches).

2.1 Physical layout

Figure 1 (over the page) shows the front and back panel layouts. The following is a short description of the labelled items.

- 1 **POWER SWITCH**
Turns mains supply on and off.
- 2 **DMX IN CONNECTOR**
DMX signal input from control desk.
- 3 **DMX OUT CONNECTOR**
DMX 'through' signal for 'daisy-chain' distribution to other DDXs.
- 4 **ON LED**
Low voltage supply OK and software initialisations completed.
- 5 **3-DIGIT LED DISPLAY**
Optical interface between DDX-60SD and operator.
- 6 **SIGNAL LED**
Visual indicator of DMX reception. Remains lit when receiving signal.
- 7 **'-' SWITCH**
Used for changing banks. Decrements the number in the LED Display.
- 8 **'+' SWITCH**
Used for changing banks. Increments the number in the LED Display.
- 9 **'SEL' SWITCH**
Must be pressed with the '+' or '-' switch to change banks. Acts as an 'escape' switch when DDX-60SD is in Test mode.
- 10 **SOCAPEX OUTPUT CONNECTORS**
Thirty sequential outputs appear on each of these two connectors.
- 11 **DIN OUTPUT CONNECTORS**
Six sequential outputs appear on each of these ten connectors.
- 12 **POWER INLET SOCKET**
Standard IEC power inlet with integral fuse holder. Only replace fuse with 2Amp M205 type.

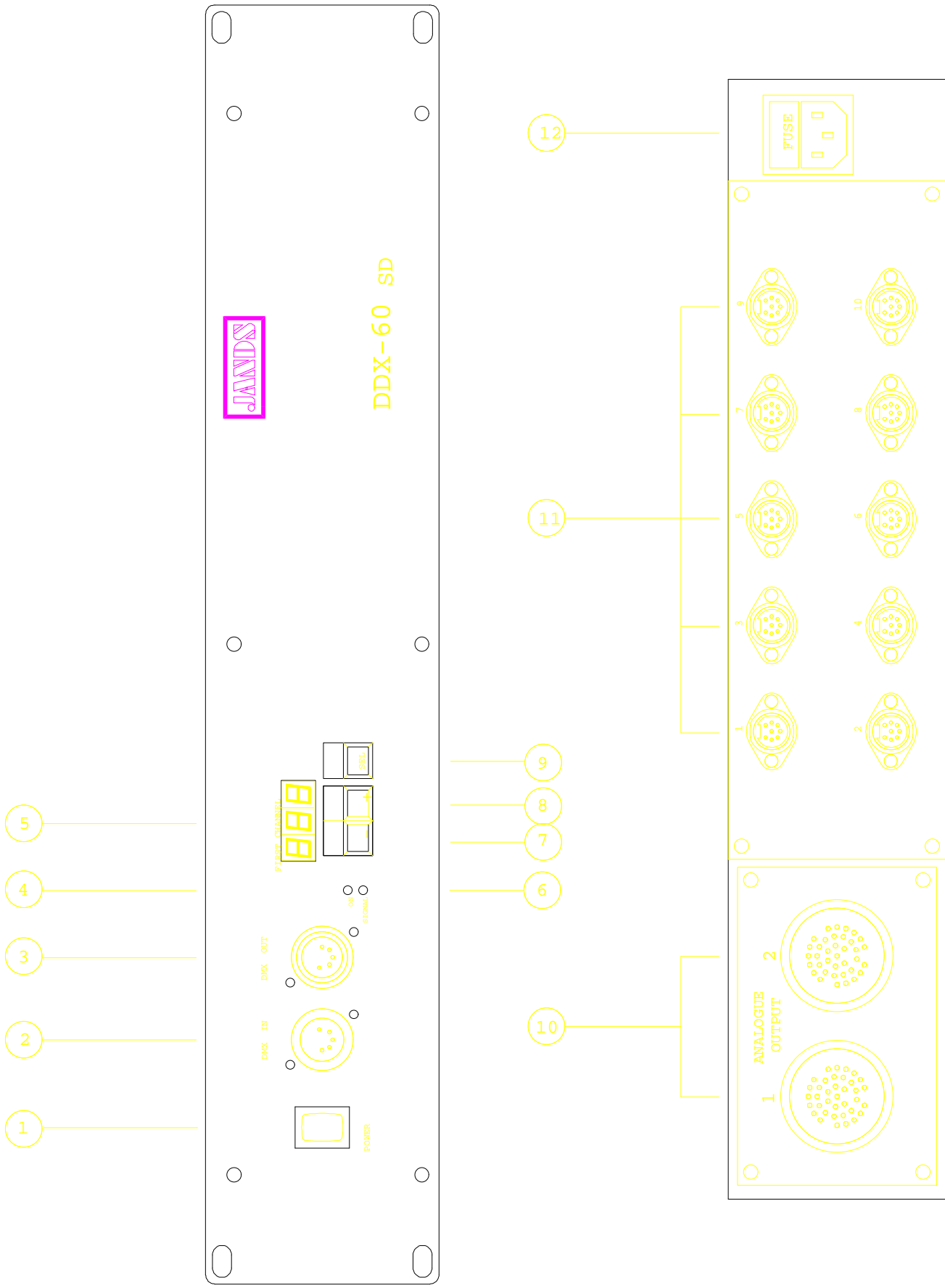

Figure 2.1 DDX-60SD Front and back panel layout

Error!**Bookmark****not****defined.**

3. Powering up

Switch the front panel "POWER" switch on. The red "POWER" LED will light if the DDX-60SD is operating. Turn off, connect a digital control source, and turn on again. The green "SIGNAL" LED will light if the digital control data is of the correct protocol and data rate.

3.1 To select a bank

The DDX-60SD selects a bank of 60 sequential channels from the possible 512 available on the DMX-512 line and shows the number of the first decoded channel on the 3-digit LED display. The '+' and '-' switches on the front panel are used to select which bank of 60 channels will be output. To prevent accidental changing of these switches once set, the 'SElect' switch must be pressed with the '+' or '-' to change the bank. '+' and 'SEL' will increment the start channel, whilst '-' and 'SEL' will decrement it. Holding both switches down will fast increment or fast decrement the display. Pressing all three switches together will reset the display to channel 1.

eg. If the display shows '13', then the DDX-60SD channel 1 output will be channel 13 of the received DMX signal. Channel 60 will therefore be channel 72 of the DMX signal. If the '-' and 'SEL' switches are now pressed, the display will show '12' as the first channel to be decoded, so DDX-60SD channel 1 output corresponds to channel 12 of the DMX, and DDX-60SD channel 60 output will be channel 71 of the DMX.

Note:

If desired, more than one DDX-60SD can be set to the same or overlapping banks, resulting in parallel outputs.

3.2 Final test

The DDX-60SD is now ready for use. Connect and turn on the dimmers.

When POWERING UP any system, the sequence to be followed should be:

- First the control DESK
- then DDX-60SDs and any other demultiplexers,
- then DIMMERS and all other receivers.

This minimises the chances of producing the lighting equivalent of an audio 'thump' and prevents damage to sensitive devices such as colour scrollers. This also extends lamp and dimmer life.

Use the REVERSE procedure when POWERING DOWN.

3.3 Normal operation

The green "SIGNAL" LED lights when the data is updated. If the LED does not light or flashes, refer to the FAULT DIAGNOSIS TABLE in Chapter 4.

If the control console stops transmitting or the control line is severed, the DDX-60SD holds the levels present immediately prior to the data loss. The hold period is determined by the state of the memory backup battery. When the battery is getting towards the end of its life, the DDX-60SD will alert the user by displaying `bAt' on the LED display immediately after being turned on. This display will remain active until the `SEL' switch is pressed, after which the DDX-60SD will resume normal operation. If the Low Battery indicator is displayed, the internal battery should be replaced to prevent the DDX-60SD forgetting its settings when turned off.

3.4 `Snapshot' backup operation

The DDX-60SD provides an emergency backup mode for the situation where the control desk `crashes' or the DMX signal is interrupted for some time. The DDX-60SD will hold the last received transmission in memory, but if this is not suitable for the activity on stage, the DDX-60SD can recall a pre-recorded `Snapshot' of up to 512 channels.

RECORD:

To record a Snapshot, the DDX-60SD must be receiving DMX. The green Signal LED will confirm this. Turn off the Power switch and turn on again with the `-' and `SEL' switches pressed. The display should now show `???''. Pressing the `+' switch will record the DMX information into the Snapshot memory and the display will show `SnP' for 1 second as verification, before reverting to the normal display.

REPLAY:

Turn off the DDX-60SD and turn on again with all three switches pressed. The display will be as per normal, except the signal LED will be off. The bank may be changed as per normal operation. To revert to normal operation, reset the DDX-60SD by turning the Power switch off and then back on. The Signal LED should come on to indicate receiving of DMX once more.

CLEAR:

To clear a Snapshot, turn off the Power switch and turn on again with the `-' and `SEL' switches pressed. The display should now show `???''. Pressing the `-' switch will clear the DMX information stored in the Snapshot memory to all zeroes and the display will show `CLr' for 2 seconds as verification, before reverting to the normal display.

3.5 Test modes

There are four Test modes on the DDX-60SD to assist with lamp patching and focusing, and also troubleshooting. When in these Test modes the Display will show a `t' in the left digit.

TEST 1:

Test 1 is accessed by turning on the DDX-60SD with the `SEL' switch pressed. The display will show `t 1', and channel 1 output will be turned on at full. Pressing the `+' switch will turn on channel 2 output and turn off channel 1. Pressing `+' again will turn on channel 3 output, etc. Pressing the `- ' switch decrements the channel output. Decrementing channel 1 will wrap the display around to channel 60.

This mode enables the lamps to be tested or focused without the need for a lighting console to be connected.

TEST 2:

Test 2 is accessed by turning on the DDX-60SD with the `+' switch pressed, or by pressing `SEL' when in Test 1. This test automatically turns on and off each channel in sequence. The rate can be changed with the `+' and `- ' switches, with four rates available from slow to fast.

TEST 3:

Test 3 is accessed by turning on the DDX-60SD with the `+' and `SEL' switches pressed, or by pressing `SEL' when in Test 2. This test continuously fades up and down the selected channel from off to full to off to full etc. Pressing the `+' and `- ' switches changes the selected channel.

TEST 4:

Test 4 is accessed by turning on the DDX-60SD with the `- ' switch pressed, or by pressing `SEL' when in Test 3. This test displays, in Hexadecimal (00 to FF), the DMX level information for a selected channel of the first 60 DMX channels. Pressing `+' or `- ' changes the selected channel. The selected channel number is displayed whilst the switch is held down, and the channel level is displayed on releasing the switch. Pressing `SEL' exits to Snapshot. If Snapshot is not required, press `SEL' once more to exit Test mode.

3.6 Interruptions

Should the DMX cable become disconnected or the control console stop transmitting, the DDX-60SD will continue to output the last received information until switched off. When reconnected to a working DMX source, the outputs will be updated.

If the mains power to the DDX-60SD is interrupted, the unit will retain the same bank settings and Snapshot when turned on again (provided the internal battery is not flat).

4. Fault diagnosis

SYMPTOM	FAULT	SOLUTION
No Power LED (red)	Mains supply disrupted.	Connect supply.
	Power switch not on.	Turn on power switch.
	Mains fuse blown.	Replace fuse with 2A M205 fuse.
Power LED (red) on but not Signal LED (green)	Digital Line not connected.	Plug in signal cable.
	Cable Failure.	Repair cable.
	Controlling console not transmitting.	Fault not in DDX-60SD.
Signal LED (green) on, but erratic or no output.	Cable failure.	Repair cable.
	Bank selected not valid.	Check what channels are being sent by the control desk.
	Transmission speed incorrect.	Adjust controller data speed (250k baud). Fault not in DDX-60SD.

5. Installation

Before leaving the factory each and every JANDS product is carefully tested and inspected for physical imperfections. As soon as your unit shipment is received, please check for any damage incurred during transit. If any damage has occurred, immediately notify the transport company and your dealer so that a claim to cover damages may be initiated. Be sure to retain the shipping carton and all packaging material for the transporter's inspection. Even if no damage has occurred, it is an advantage to retain the packaging materials should you have occasion to ship the unit.

5.1 Mains supply

The power supply in the DDX-60SD is a universal switching type, and will run reliably from mains voltages of 90 volts to 260 volts AC. There is no need for the user to make any adjustments to the power supply or the wiring.

5.2 Output voltage adjustment

As supplied, a DDX-60SD will deliver +10 volts DC at full output. This may be adjusted over the range +9V to +11V if required to interface to non-standard equipment. If so, remove the lid (8 screws) and set up the DDX-60SD for Test 1 (see section 3.5). Referring to Figure 5.1, adjust the output level trim (VR1) to give the required output voltage measured at pin 1 of the first connector. All channels will now output to this level.

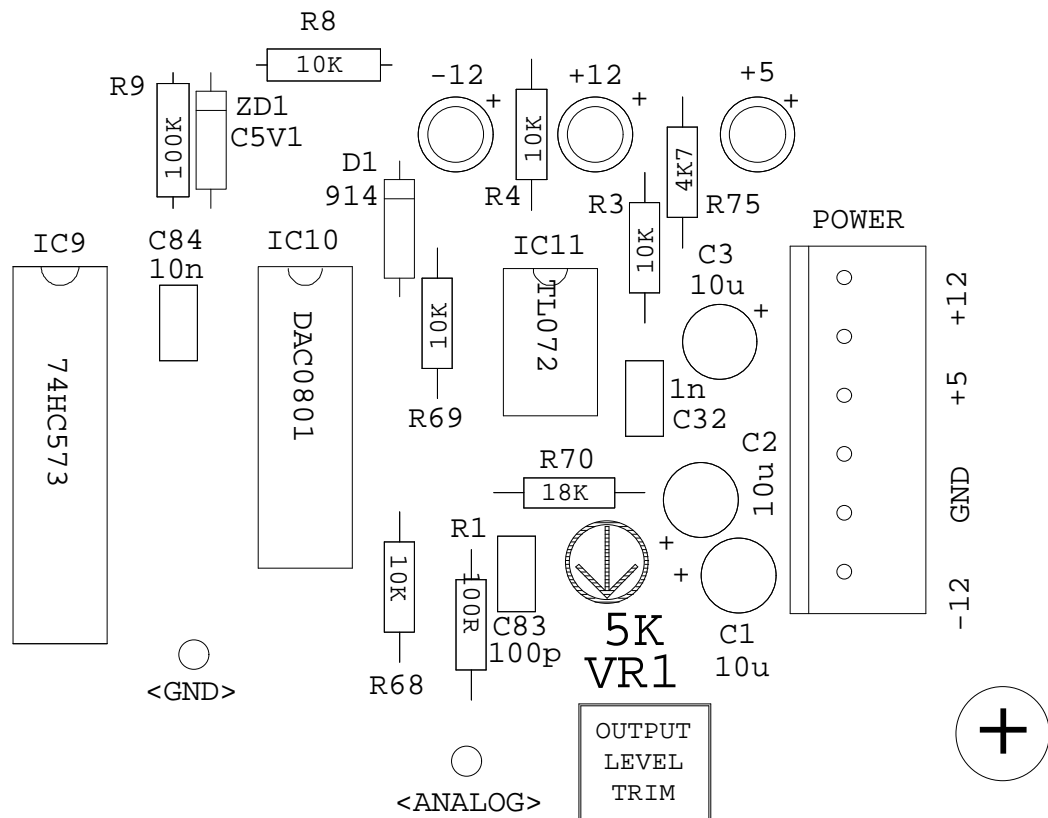

Figure 5.1 Output voltage adjustment

5.3 Rack mounting

The DDX-60SD has been designed to be installed in a standard 19" rack, and occupies two rack spaces. When mounted with dimmers, it should be placed beneath the dimmers to minimise heat built-up. Slide the unit into its position in the rack, and secure using the four rack screws supplied.

5.4 Wiring

If more than one DDX-60SD is to be used from the one control desk, plug a daisy-chain lead from the first DDX-60SD "DMX OUT" socket to the next "DMX IN" socket. The DIN analogue outputs are arranged in ten groups of six channels, to simplify the interface between the DDX-60SD and 12-channel dimmers. Plug in the appropriate leads and secure the retaining rings. Again, the leads should be wired as in section 7.2.

6. Maintenance Instructions

With care, the DDX-60SD will require little or no maintenance. If a fault develops refer to the FAULT DIAGNOSIS TABLE in Chapter 4. If the unit will still not perform as described, the DDX-60SD should be taken to an authorised JANDS distributor for professional service.

6.1 Cleaning

Use a damp paper towel or soft cloth with a mild detergent and water to wipe clean the external surfaces, taking care to prevent any water entering the chassis.

6.2 Guarantee

Each and every JANDS product is guaranteed against defects in material and workmanship for a period of two years in Australia. Consult your distributor for overseas warranty details. In Australia, JANDS will replace defective parts and make necessary repairs under this warranty if our examination reveals evidence of faulty workmanship or material. The warranty does not cover damage caused by misuse, accident or neglect, or if the serial number has been defaced or removed. The warranty card included with each unit sets out the conditions of the warranty. There is no need to return this card. Your bill of sale is sufficient to establish warranty. Should there be a need to ship the unit to the JANDS factory for repair, the unit must be shipped in its original package (or a replacement which is available at a small cost) and all freight charges must be pre-paid. If a warranty is established the unit will be repaired and returned freight collect.

7. Specifications

Digital Control	5 Pin XLR
Input/Output Connectors	Pin 1 - Shield Pin 2 - Cold Pin 3 - Hot Pin 4 - Spare Cold Pin 5 - Spare Hot
Input Signal	Electrically must conform to RS458A specification
Data Protocol	Must conform to full speed USITT DMX-512 1990 specification (250K baud). 1 start bit, 8 data bits, 2 stop bits, no parity.
Maximum Digital Control line Length	Undefined due to variation in cable parameters. With high quality cable, over 500 metres can be obtained.
Suitable Cable Types	HARTLAND HC2522 (1 pair, no spares). BELDEN 8101 or equivalent (1 pair, no spares). BELDEN 8102 or equivalent (2 pairs, spares provided).
Channel Output	0 (off) to +10 VDC (full) on back panel DIN or Socapex connectors, short circuit protected.
Output Error	10% for 1k load. Less than 1% for 10k ohm or greater load (typical).
Update Rate	Dependent upon controller.
Front Panel LED Indicators	POWER (red) and SIGNAL (green)
Power	90-260V AC 50-60Hz, 25W maximum.
Mains Fuse	2A M205.
Size (mm)	19" wide x 3.5" high (2 Rack Units) (483mm wide x 89mm high x 290mm deep)
Weight	4.8 kilograms

7.1 Spare parts and accessories

SPARE PARTS	QTY per DDX-60SD	PART NUMBER
Pushbutton Switch	3	EC314
Switch cap (state which symbol reqd)	3	EC383
Power Switch	1	EC262
Fused IEC mains socket	1	PC253
Fuse - 240 VAC 2A M205	1	EF520
25 Watt Switching PSU	1	SMPSDDX60
3 volt battery	1	DC007
Male 5 Pin XLR chassis mt Black	1	MO534B
Female 5 Pin XLR chassis mt Black	1	MO531B
Frnt pnl screws M4x10 Black button hd	6	
DIN output panel	1	
DIN output panel blank plate (optional)		
Socapex output panel (optional)		
Socapex output panel blank plate (optional)		

ACCESSORIES	QTY REQD	PART NUMBER
Male 5 Pin XLR in line (Cannon)	1	AXR512
Female 5 Pin XLR in line (Cannon)	1	AXR511
Rack Mount Kit Cage Nuts (50)	4	1557
Rack Mount 3/16 x 3/4 screws (50)	4	1559
Digital Control Cable	30 metres	
	50 metres	
	75 metres	
	100 metres	

7.2 Connector pin terminations

DIGITAL CONTROL LINE INPUT

XLR CONNECTOR PIN (MALE)	SIGNAL
1	SHIELD
2	RECEIVE -VE
3	RECEIVE +VE
4	SPARE
5	SPARE

DIGITAL CONTROL LINE OUTPUT

XLR CONNECTOR PIN (FEMALE)	SIGNAL
1	SHIELD
2	TRANSMIT -VE
3	TRANSMIT +VE
4	SPARE
5	SPARE

It is recommended that the specified cable type be used in all conditions. However, for short runs other cable types will operate successfully. Experimentation is the best method for determining the suitability of a cable. Note that the cable must have two cores within the shield.

Note also that digital control cables should NEVER be 'Y' split to obtain two outputs. If more than one output is required, an active splitter-box should be used.

ANALOGUE OUTPUT CONNECTORS

DIN		CHANNEL OUTPUT									
CONNECTOR	CONN	CONN	CONN	CONN	CONN	CONN	CONN	CONN	CONN	CONN	CONN
PIN No.	1	2	3	4	5	6	7	8	9	10	
1	1	7	13	19	25	31	37	43	49	55	
2	2	8	14	20	26	32	38	44	50	56	
3	3	9	15	21	27	33	39	45	51	57	
4	4	10	16	22	28	34	40	46	52	58	
5	5	11	17	23	29	35	41	47	53	59	
6	6	12	18	24	30	36	42	48	54	60	
7	NC	NC	NC	NC	NC	NC	NC	NC	NC	NC	
8	GND	GND	GND	GND	GND	GND	GND	GND	GND	GND	

Note:

Channel Output only valid if FIRST CHANNEL display is set to channel 1.

SOCAPEX CONNECTOR PIN No.	CHANNEL OUTPUT	
	CONN 1	CONN 2
1	1	31
2	2	32
3	3	33
4	4	34
5	5	35
6	6	36
7	7	37
8	8	38
9	9	39
10	10	40
11	11	41
12	12	42
13	13	43
14	14	44
15	15	45
16	16	46
17	17	47
18	18	48
19	19	49
20	20	50
21	21	51
22	22	52
23	23	53
24	24	54
25	25	55
26	26	56
27	27	57
28	28	58
29	29	59
30	30	60
31	NC	NC
32	NC	NC
33	NC	NC
34	GND	GND
35	GND	GND
36	NC	NC
37	GND	GND

It is recommended that all unused pins be connected to ground.

