

# Event 4 Technical Manual

---

**EMC COMPLIANCE**

---



This product is approved for use in Europe and Australia/New Zealand and conforms to the following standards: AS/NZS 4251.1 (EN 55103-1), AS/NZS 4252.1 (EN 55103-2), AS/NZS 3260 (EN 60950).

To ensure continued compliance with EMC Directive 89/336 and the Australian Radio communications Act 1992, use only high quality data cables with continuous shield, and connectors with conductive back shells. Examples of such cables are:

DMX, MIDI, Keyboard cables:	Belden 8102	100% Aluminium foil screen, 65% Copper braid.
Video:	Amtron FR2651	Flat round cable, woven shield.

---

NOTE: This equipment has been tested and found to comply with the limits for a Class B digital device, pursuant to Part 15 of the FCC Rules. These limits are designed to provide reasonable protection against harmful interference in a residential installation. This equipment generates, uses and can radiate radio frequency energy and, if not properly installed and used in accordance with the instructions, may cause harmful interference to radio communications. However, there is no guarantee that interference will not occur in a particular installation. If this equipment does cause harmful interference to radio or television reception, which can be determined by turning the equipment off and on, the user is encouraged to try to correct the interference by one or more of the following measures:

- reorient or relocate the receiving antenna;
- increase the separation between the equipment and receiver;
- connect the equipment into an outlet on a different circuit from that to which the receiver is connected;
- consult the dealer or an experienced radio/television technician for help.

---

This Class B digital apparatus complies with Canadian ICES-003.

Cet appareil numérique de la classe B est conforme à la norme NMB-003 du

---

© JANDS ELECTRONICS PTY LTD 1999

All rights reserved

**DISCLAIMER**

Information contained in this manual is subject to change without notice and does not represent a commitment on the part of the vendor. JANDS ELECTRONICS P/L shall not be liable for any loss or damage whatsoever arising from the use of information or any error contained in this manual.

It is recommended that all service and repairs on this product be carried out by JANDS ELECTRONICS P/L or it's authorised service agents. JANDS ELECTRONICS P/L cannot accept any liability whatsoever for any loss or damage caused by service, maintenance or repair by unauthorised personnel, or by use other than that intended by the manufacturer. JANDS lighting consoles must only be used for the purpose they were intended by the manufacturer and in conjunction with the operating manual.

Manufactured in Australia by JANDS Electronics Pty Ltd (ACN 001 187 837)  
 40 Kent Rd (Locked Bag 15)  
 MASCOT NSW 2020  
 Sydney Australia

PHONE:+61-2-9582-0909 FAX:+61-2-9582-0999 INTERNET:<http://www.jands.com.au>

# Table of Contents

<b>Table of Contents .....</b>	<b>iii</b>
<b>1. Introduction.....</b>	<b>1-1</b>
<b>2. Equipment Description .....</b>	<b>2-1</b>
2.1 Tools.....	2-1
2.2 Disassembly .....	2-1
2.3 Reassembly .....	2-2
2.4 Precautions and Installation Notes .....	2-2
<b>3. Circuit Notes .....</b>	<b>3-1</b>
3.1 Processor Card .....	3-1
3.1.1 Boot ROM, FLASH, and RAM .....	3-1
3.1.2 Trim procedure.....	3-1
3.1.3 Battery .....	3-2
3.1.4 Logic .....	3-2
3.1.5 Desk Lamp Dimmer.....	3-2
3.1.6 DMX Outputs.....	3-2
3.1.7 Keyboard .....	3-2
3.1.8 Expansion Bus.....	3-3
3.2 Front Panel Cards.....	3-3
3.2.1 Card Select Jumpers.....	3-3
3.2.2 LCDs .....	3-3
<b>4. DIP Switch Settings.....</b>	<b>4-1</b>
<b>5. Boot ROM inbuilt menu, self tests, setups, etc .....</b>	<b>5-1</b>
5.1 Entering the Boot Menu .....	5-1
5.2 Menu Usage .....	5-1
5.3 Boot Menu.....	5-1
5.3.1 Continue.....	5-1
5.3.2 Reload Software.....	5-1
5.3.3 Test.....	5-2
CPU.....	5-2

---

Bus .....	5-2
RAM.....	5-4
FLASH.....	5-4
VGA .....	5-4
Ports .....	5-4
VGA .....	5-4
DMX 1 .....	5-4
DMX 2 .....	5-4
MIDI.....	5-5
Cards .....	5-5
Scan.....	5-5
Activate .....	5-5
Misc.....	5-6
DMX In.....	5-6
Vers .....	5-6
Trash RAM .....	5-6
Boot.....	5-6
<b>6. Fault Finding Table.....</b>	<b>6-1</b>
<b>7. Maintenance.....</b>	<b>7-1</b>
<b>8. Technical Data and Specifications.....</b>	<b>8-1</b>
Event 4 Specifications .....	8-1
<b>9. Glossary of Terms .....</b>	<b>9-1</b>
<b>Appendix A: History of Modifications .....</b>	<b>9-1</b>
<b>Appendix B: Connector Pinouts.....</b>	<b>9-1</b>
<b>Appendix C: Spare Parts.....</b>	<b>9-1</b>
<b>Appendix D: DMX to MIDI adaptor.....</b>	<b>9-1</b>
<b>Appendix E: 2 x DMX, MIDI signal combiner .....</b>	<b>9-1</b>
<b>Appendix F: Circuit diagrams.....</b>	<b>9-1</b>

---

---

<b>EV4CPU1 Circuit diagrams .....</b>	<b>9-2</b>
<b>EV4MAST3 Circuit diagrams.....</b>	<b>9-3</b>
<b>EV4ASN3 Circuit diagrams .....</b>	<b>9-4</b>
<b>EV4PRE3 Circuit diagrams .....</b>	<b>9-5</b>
<b>EV4PAL3 Circuit diagrams.....</b>	<b>9-6</b>
<b>BKLTSMLO Circuit diagrams .....</b>	<b>9-7</b>

# 1. Introduction

The Event 4 lighting control console is designed for stage, theatre, corporate, and live music applications. It has been designed to control all equipment with a DMX-512 input. New fixture types can be added by modifying the fixture library disk if they are not available on the existing release library.

The console has been designed with the capability for users to upgrade the software without removing the base. This is achieved by inserting a diskette with the new operating system, and selecting the appropriate options in the "boot menu". The boot menu also provides other functions, including console self tests.

Note that static sensitive devices are used throughout the console, and normal handling precautions should be applied during service. Note also that connections should never be made with the power switched on.

Metric fasteners are used almost exclusively throughout the console.

The Event 4 Operating Manual should be consulted for a description of desk operation.

Jands recommends that all service procedures be performed by a Factory Authorised Service Centre or the Jands Electronics Service Department.

## 2. Equipment Description

The Event 4 is constructed using a folded steel chassis, covered with a reverse screened lexan. The decorative wooden ends are made from plantation growth native Australian timber mounted on an aluminium former, which provides structural rigidity. The timber also protects the fascia of the floppy disk drive. An additional pair of front to back struts reduce flex and ensure front to back spacing is consistent with the base.

A separate assembly is used to hold the power supply (PSU) and central processor (CPU) cards. This bracket is removable as a complete pre-wired unit. A backpanel vent next to the CPU card is removable from the inside and can be used to fit options.

### 2.1 Tools

With the exception of the base screws and D connector mounting nuts, metric hardware is used throughout the console. The following tools are recommended:

- 7mm nut driver
- 5mm nut driver
- #1 Posidrive screwdriver
- #2 Posidrive screwdriver

### 2.2 Disassembly

Access to the console is through the base. To remove the base place the console face down onto soft padding. Using the #2 posidrive screwdriver remove all (and only) the silver screws, leaving the four black screws. The base can then be lifted away.

To remove the PSU/CPU assembly, disconnect all cables to the CPU and PSU, and use the 7mm nut driver to undo:

- three nuts next to the power inlet socket,
- two nuts between the PSU and CPU,
- three nuts between the CPU card and the vent/option panel

Use the posidrive screwdriver to undo:

- two screws that hold the CPU tray to the chassis.

The assembly can then be removed by sliding it toward the front until it is clear of the studs, then lifting it out of the chassis.

Note that the CPU card can be removed from the console without removing the complete assembly. To remove the CPU card from the assembly:

- Remove all connections to the card
- Undo the D connector nuts
- Undo the nine PCB mounting screws
- Slide the CPU card away from the back panel until the D connectors are clear of the assembly, and lift the CPU away.

The remaining PCBs may be removed by undoing the relevant screws, however attention should be made to the following points:

- Faders should be pushed to their mid position **before** their knob is removed. Failure to do so may result in damaged faders.
- The position of the address jumpers on the Palette and Assign cards should be noted when they are removed so they can be correctly set during reassembly

## 2.3 Reassembly

Attention should be paid to the following during reassembly:

- LCDs and their windows should be wiped clean with a lint-free cloth before assembly.
- Ensure the address jumper on Palette and Assign cards are set correctly. Note all cards should only ever have one (1) address jumper installed. Refer to section 3.2.1 for further information on the card select jumper settings.
- When fitting the CPU ensure all connectors are properly installed, including the DMX output connector. Also check that the DMX connector wiring is located within the cutout section of the CPU card.
- The CPU trim procedure should be followed if either the CPU or power supply have been changed, or if the trim has been inadvertently adjusted. Refer to section 3.1.2.
- Test the console fully before installing the base. This includes the disk drive, desk lamps, back lights, and DMX outputs.
- Double check all flatcable latch connectors are closed before the base is installed.
- Do not overtighten the base screws.

## 2.4 Precautions and Installation Notes

The Event 4 should be installed in a position which allows sufficient ventilation around the back panel vents – there should be at least 100mm clear space around the back panel.

The Event 4 has been manufactured to comply with all CE/C-Tick regulations, and uses plated panels to ensure minimal radiation emanates from the chassis. In order to maintain compliance all panels and covers should be attached using all screws. All connections should be made using the recommended cable type. All back shells should be connected to the cable shield.

## 3. Circuit Notes

The Event 4 uses a main CPU to provide all processing functions. The CPU communicates with the front panel PCBs via the front panel card bus.

### 3.1 Processor Card

The major functional blocks are as follows:

Function	IC Number
Core CPU	IC1-8, IC33, IC30, OSC1
Boot EPROM	IC25
FLASH ROM	IC11-14
RAM Bank 1	IC16-19
Floppy Disk Drive Controller	IC48
DMX output	IC53, IC38, IC39, IC50, IC51
MIDI	IC48, IC35, IC52
VGA output	IC6, IC57-60, IC66
Reset/power fail/RAM power	IC15
Real time clock	IC31
Front Panel Card bus	IC9, IC10
Expansion bus	IC24, IC26-29

#### 3.1.1 Boot ROM, FLASH, and RAM

The CPU memory consists of a Boot EPROM (IC25), four FLASH ROMs (IC11, IC12, IC13, IC14), and four static RAMs (IC16-19).

The CPU card has the capacity to be fitted with a maximum of 2MBytes program memory (four x 29F040 devices) and 2MBytes show memory (four x 512Kbyte devices).

Only AMD brand 29F040 FLASH devices should be used with boot software versions up to 0.5.

#### 3.1.2 Trim procedure

The adjustment trim on the CPU card adjusts the point where the CPU is informed that power is failing. If a console is dropping its memory, trimpot T1 may be out of adjustment and should be adjusted as follows:

1. Save any necessary console information to diskette
2. Turn T1 fully anticlockwise
3. Place a shunt across J1
4. Switch console on and wait until it has completely started up
5. Slowly adjust T1 until LED L3 lights

6. Switch off console.
7. Remove shunt across J1

This procedure should be performed whenever either a new CPU or PSU is installed.

### 3.1.3 Battery

The lithium battery should last approximately 5 years **from the date the battery was made** - note that a 4 year life from date of product sale would not be unexpected when delivery and manufacturing times are allowed for. The battery should be considered flat if its terminal voltage measures below 2.9 volts. Backup any required show data to diskette before the battery is replaced.

#### CAUTION

**Danger of explosion if battery is incorrectly replaced.**

**Replace only with the same or equivalent type recommended by the battery manufacturer. Dispose of used batteries according to the battery manufacturer's instructions.**

### 3.1.4 Logic

The logic requirements for the board are contained in two logic devices, IC33 and IC53. These are in circuit programmable, and are programmed by connecting an appropriate header to CONN3. If it is necessary to reprogram these devices in the field, follow the instructions supplied with the kit.

### 3.1.5 Desk Lamp Dimmer

The desk lamp dimmer circuit consists of a PWM switching circuit protected by a PTC polyswitch. The polyswitch will trip under overload conditions – when it does LED L6 will extinguish. Due to the nature of the polyswitch it is necessary to either disconnect all desk lamps or switch the console off for approximately one minute in order for it to reset.

### 3.1.6 DMX Outputs

The DMX outputs are not opto-isolated, however a protection network decouples the driver ICs from high voltages which may be applied during external mains faults. After a fault has been removed these devices take approximately one minute to reset, and during this time the output cables should be disconnected or the console switched off.

### 3.1.7 Keyboard

The console is protected against excessive load current through the keyboard connector by a polyswitch. After a fault has been removed this device takes approximately one minute to reset, and during this time the keyboard should be disconnected or the console switched off.

### 3.1.8 Expansion Bus

The expansion bus is provided to allow for options to be added in the future. The expansion bus is a buffered extension of the system CPU bus. It is **not** compatible with Jandshog, Event, or ESP2 type expansion bus option panels, and **they should not ever** be installed.

## 3.2 Front Panel Cards

All front panel cards follow a design similar to that of other Jands consoles. A multiplexed 8 bit data/address bus is used to exchange bytes of information between the CPU and the front panel cards. The pin connections however are not compatible and under no circumstances should Event, ESP2, and Jandshog type front panel circuit boards ever be connected to an Event 4 CPU card. Damage will result.

### 3.2.1 Card Select Jumpers

A jumper on each Preset and Assign card selects the address of the card in the system. When installing new cards ensure that the replacement card has its jumper in the same position as the card it is replacing.

The correct jumper position for a Preset or Assign card is equal to its position from the left eg. the left most Preset and Assign cards have their jumpers set to 0, the next have it set to 1, etc. Master and Palette cards have no address jumper.

### 3.2.2 LCDs

The character LCD modules use a single backlight driver circuit to deliver the high voltage required for all of the electroluminescent (EL) backlights. This is the function of the EL driver board, mounted near the power supply. This board receives its power and an analogue control from the CPU card.

Note that intensity of the character LCD backlights reduces with age. This is normal and to minimise the reduction the backlights are deactivated if the console hasn't been used for a preset time. The backlights are immediately reactivated when any front panel button is pressed.

## 4. DIP Switch Settings

**NOTE: At the time of printing all DIP switches should be off for normal console operation.**

Dip SW1 - no function

Dip SW2 - no function

Dip SW3 - no function

Dip SW4 - no function

Dip SW5 - no function

Dip SW6 - Enable main code diagnostics

Dip SW7 - Execute software from RAM – use for development only

Dip SW8 - Reserved

# 5. Boot ROM inbuilt menu, self tests, setups, etc

The Boot ROM contains software that can be used to test, setup, and configure the console. Note that the software is subject to change depending on the boot software version.

## 5.1 Entering the Boot Menu

The boot menu is accessed by holding down the “RECORD” button on the keypad while turning power on. Release the Record button when the opening menu is displayed in the programmer LCD.

## 5.2 Menu Usage

Each menu offers a number of options available. The options are selected by pressing one of the five buttons above the programmer LCD, or press EXIT to return to the previous menu.

## 5.3 Boot Menu

The following menu options are available in the opening menu

1. Continue
2. Load FLASH
3. Test

### 5.3.1 Continue

Use this option to exit the boot menu and continue normal execution into the main operating software. Use this option if the boot menu has been entered by mistake.

### 5.3.2 Reload Software

Selecting the Load FLASH option initiates the software reload sequence from diskette. Ensure you have an Event 4 software diskette with the file “EVENT4.BIN in the drive and follow the instructions on the LCD. Note that this facility should be used with caution and it is not recommended that software be reloaded at a critical time, eg. just before the start of a show.

### 5.3.3 Test

The following menu options are available in the Test menu:

1. CPU
2. Ports
3. Cards
4. Misc
5. Boot

Tests may be run continuously or once as required.

#### CPU

Use this option to test parts of the CPU card. When selected the following options are displayed:

1. Bus
2. RAM
3. FLASH
4. VGA

#### Bus

The Bus exercise is not a test as such, but is used to debug CPU cards that have fundamental faults, such as factory testing of newly manufactured CPU cards.

The CPU has been programmed to output sequences of events that can be seen on a CRO, synchronised to the edge of L5 and L4. The data can be used to verify the correct operation of the CPU control signals.

The sequence of operations performed during this routine are shown in table 3.

Event	Signals of interest	Comment
Set Green LED L5 on	L5	CRO Synchronisation
Set Green LED L5 off	L5	CRO Synchronisation
Move 01 to 40010004	IC16 pin 29	Write to RAM bank 0 byte 0
Move 02 to 40010005	IC17 pin 29	Write to RAM bank 0 byte 1
Move 04 to 40010006	IC18 pin 29	Write to RAM bank 0 byte 2
Move 08 to 40010007	IC19 pin 29	Write to RAM bank 0 byte 3
Move 40010004 to CPU	IC16-19 pin 24	Read from RAM bank 0
Set Red LED L4 on	L4	CRO Synchronisation
Set Red LED L4 off	L4	CRO Synchronisation
Move 10 to 20000000	IC13 pin 29	Write to FLASH byte 0
Move 20 to 20000001	IC14 pin 29	Write to FLASH byte 1
Move 40 to 20000002	IC12 pin 29	Write to FLASH byte 2

Move 80 to 20000003	IC11 pin 29	Write to FLASH byte 3
Move 20000004 to CPU	IC11-14 pin 24	Read from FLASH
Move AA to 606A0000	IC65 pin 13	PC Memory Write
Move 606A0000 to CPU	IC65 pin 14	PC Memory Read
Move 55 to 60000000	IC65 pin 50	PC IO Write
Move 60000000 to CPU	IC65 pin 49	PC IO Read

Table 3: Bus exercise event summary

Figure 1 shows the relationship between L5, IC16 WR, and the CPU DACK signals as measured while running this test.

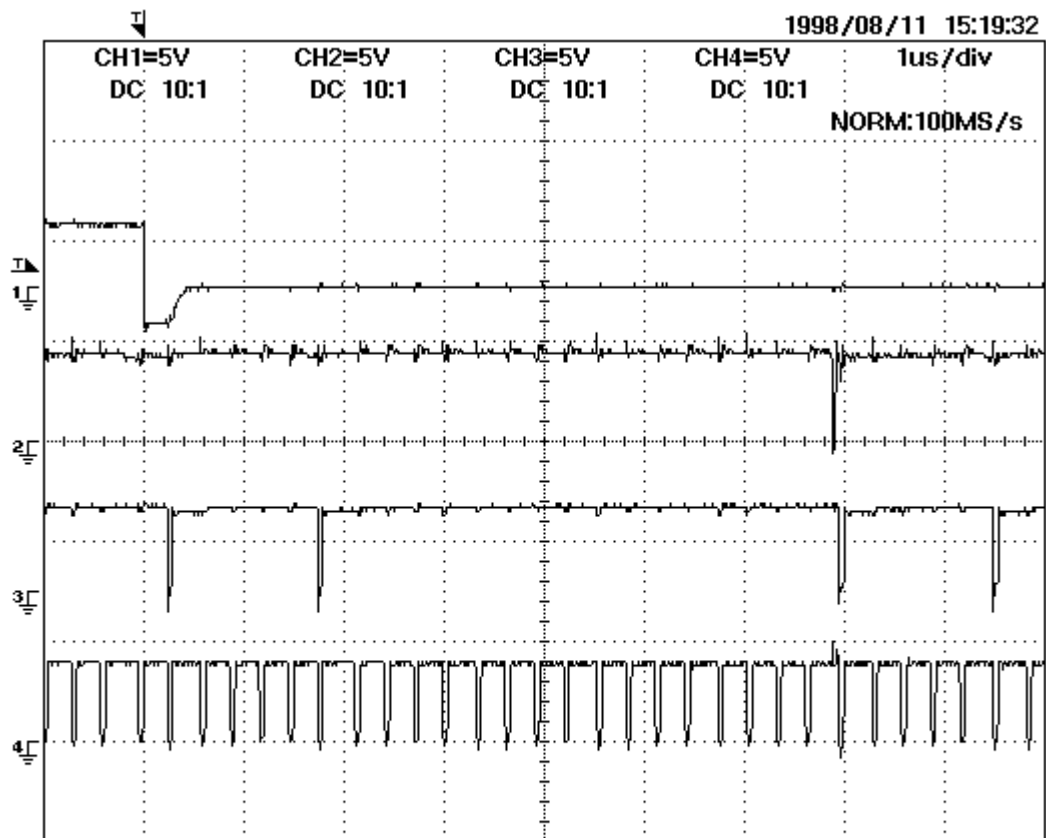

<b>=Filter=</b>	<b>=Offset=</b>	<b>=Record Length=</b>	<b>=Trigger=</b>
Smoothing : OFF	CH1 : 0.00V	Main : 1K	Mode : AUTO
BW : FULL	CH2 : 0.00V	Zoom : 100	Type : EDGE CH1 $\Psi$
	CH3 : 0.00V		Delay : 0.0ns
	CH4 : 0.00V		Hold Off : MINIMUM

Figure 1: Sample waveform during Bus Exercise

- Trace #1: L5
- Trace #2: IC16 Pin 29 (WR)
- Trace #3: IC1 pin 44 (DACK1)
- Trace #4: IC1 pin 43 (DACK0)

## RAM

The system RAM is checked for correct operation. This test requires approximately 2 minutes to execute.

## FLASH

The system FLASH is checked for correct operation. This test requires approximately 50 seconds to execute. Note that due to the limited number of write cycles available in FLASH devices, it is not recommended that this test be run continuously.

## VGA

The VGA controller is initialised and a memory test is performed on its RAM. This test takes approximately 17 seconds to execute and during execution a VGA monitor will show the memory test patterns.

## Ports

Use this option to test the ports of the CPU card. When selected the following options are displayed:

1. VGA
2. DMX1
3. DMX2
4. MIDI

## VGA

Test bars are displayed on the VGA and LCD screens for the purpose of checking colour (VGA) and grey scaling (LCD). Press enter to return to the normal menu when the screen results have been viewed.

## DMX 1

The DMX1 output is connected to the MIDI input via the adaptor cable shown in Appendix D, or the combiner circuit shown in Appendix E. When the test is run the DMX1 output is exercised and the results read back into the MIDI input. The test takes about 3 seconds to complete.

## DMX 2

The DMX2 output is connected to the MIDI input via the adaptor cable shown in Appendix D, or the combiner circuit shown in Appendix E. When the test is run the DMX2 output is exercised and the results read back into the MIDI input. The test takes about 3 seconds to complete.

## MIDI

The MIDI output is connected to the MIDI input via a standard MIDI link cable. When the test is run the MIDI output is exercised and the results read back into the MIDI input. The test takes about 3 seconds to complete.

## Cards

Use this option to test the front panel cards of the console. When selected the following options are displayed:

1. Scan
2. Activate

## Scan

This test scans the front panel card bus and displays on the VDU the cards found. When run continuously this test will activate the front panel card bus and the signals can be used to troubleshoot faulty PCBs.

## Activate

When run this test activates the front panel card bus as shown in Table 4, and can be used to verify correct operation of the majority of the front panel controls. In general a pressed switch is indicated by its associated LED (or the LCD if no LED available), and fader values are displayed on the associated LCD or channel LED. The Channel master levels and preset faders operate in familiar two preset mode, with the levels appearing at both DMX outputs.

This test is terminated by pressing Exit.

Card	Control Type	Indication
Palette	Palette select	Associated LED
Assign	Flash button	Associated LED changes from green to red
Assign	Fader levels	Associated LCD
Assign	LCD contrast	Controlled by Assign Fader #1
Master	Buttons with red LED	Associated LED
Master	Buttons with Bicolour LED	Associated LED turns from green to red
Master	Buttons with no LED	LCD
Master	Wheels	LCD
Master	Faders	LCD
Preset	Faders	Associated Mimic LEDs
Preset	Flash Buttons	Associated Mimic LEDs

Table z: Front panel activation responses

## Misc

Use this option to run miscellaneous tests on the console. When selected the following options are displayed:

1. DMX In
2. Vers
3. Trash RAM

## DMX In

DMX signal from an external source is connected to the MIDI input using the adaptor cable detailed in Appendix D. The DMX signal present is displayed on the VDU. Note that both DMX outputs transmit a test data pattern that can be used to feed into the input, however only one should be plugged into the MIDI input. Note also that the data pattern changes each time the test is run.

Press Exit to terminate the test.

## Vers

The software version of the test routines is output to L4 and L5 in flashes. The green LED (L5) flashes once at the start of the test. The version is then displayed in red LED (L4) flashes. The version is also displayed on the master LCD at startup, and for this reason this test is mainly for use when no Master card is available.

## Trash RAM

The system memory is completely cleared.

## Boot

The console is restarted. This is generally used when use of the self tests has been completed and it is desired to start the main operating software. Holding the Enter button down immediately after activating this option allows re-entry to the self tests and setups.

## 6. Fault Finding Table

Symptom	Possible Cause	Remedy
<b>Console won't run</b>	Show memory corrupt Program memory corrupt Mains fuse blown	Deep Clear Reload program Replace fuse in power inlet
<b>Front panel config error on start up</b>	Flat cable disconnected  Faulty flatcable Circuit board not working	Check that all flat cable connectors are locked closed Replace flatcable Replace card
<b>Console crash with message "Address error exception" etc</b>	Software Bug	Write down message and forward to Jands, then try reboot or program reload
<b>Console drops its memory</b>	Flat battery Power fail circuit out of adjustment	Replace battery Re-trim T1 as per section 3.1.2
<b>Console always shows error</b>	Software bug	Write down message and forward to Jands, then RAM trash as described in section 5.3.3.4.3
<b>Console won't write or read diskette</b>	Disk not DOS format  Diskette damaged Poor quality diskette Diskette drive damaged	Format on a PC compatible computer (DOS 3.0 and above) Replace diskette Use quality diskette Replace diskette drive
<b>Fixture not available for patching</b>	Fixture library in console not up to date or corrupt	Load latest library from library diskette.
<b>No DMX output</b>	Incorrect patch Incorrect receiver address Faulty DMX cable No line termination Blown DMX driver	Check patch Check receiver Repair / replace cable Terminate DMX line Replace driver Patch to other DMX output
<b>Desk Lamp off</b>	Short circuit lamp  Level turned down Blown bulb	Remove short circuit then switch console off for 1 minute Adjust level Replace bulb
<b>Radio Interference</b>	Unearthed power cable Poor quality cables	Use earthed cable/outlet Use quality shielded cables
<b>No intensity control from console DMX</b>	Grand Master down DBO button active	Adjust Grand Master Press DBO button
<b>VGA monitor not working</b>	Monitor not turned on  Monitor not plugged into console	Check power connection Check power switch Check VGA connection to console

## 7. Maintenance

If a console should start to misbehave or operate erratically, the problems encountered can usually be attributed to one of two causes:

- normal wear and tear, eg. switches failing and becoming intermittent.
- physical abuse, eg. transit damage, spilt drinks, shorted cables.

Parts most likely to wear out in time with normal use include the following:

- switches
- faders
- LCD backlights
- digital encoders

These are generally easy to spot and there is little that can prevent such wear from occurring, however careful use will maximise their life. Almost all parts of the console can be damaged by physical abuse, however there are a number of things that can be done to prevent this kind of damage:

- Cover the console when not in use, eg. before, after and between sets.
- ALWAYS insert a diskette into the floppy disk drive when the console is to be transported. This prevents damage to the drive mechanism.
- Do not use spare audio lines for DMX cable. If so, there is a danger that the connector will get plugged in to the wrong signal.
- Do not smoke over the console.
- Do not obstruct the rear ventilation holes.
- When cleaning, do not use solvents and never allow the entry of liquids into the console. Use only a damp soft cloth for cleaning.

The console operating software is extremely complex. It is recommended that the console be deep cleared at the start of each new tour.

## 8. Technical Data and Specifications

Event 4 Specifications	
Mains Supply:	90-265VAC, 47-63Hz, 60 watts max.
Mains Fuse:	2A, M205 delay type
Temperature:	40°C maximum ambient
Outputs:	DMX Out 1 & 2, MIDI Thru, MIDI Out, Two Desk Lamps, VGA
Inputs:	Keyboard (AT type), MIDI In
Control channels:	36 preset fader – 360, 24 preset fader - 240
Data Protocol:	USITT DMX-512/1990, electrically conforms to RS485A.
Memory capacity:	2Mbytes
Disk Drive:	IBM format DOS 3.0 and above, 1.44MB high density
Desk Lamps:	12 volt 5 watt x 2, maximum output 10W total
Construction:	All steel chassis with lexan/polycarbonate covered control surface
Dimensions:	L: 945mm    W: 530mm    H: 110mm
Weight:	19 kg net / 24.5 kg shipping
Ingress protection:	IP20

## 9. Glossary of Terms

Abbreviation	Term	Explanation
ADC	Analogue to Digital Converter	A device for converting real world (analog) signals into digital information a micro-processor can manipulate
BOOT	BOOT	System startup
CE	Chip enable	A select pin provided on a device to enable it to be used in conjunction with a CS line
CE	Compliance mark	Equipment marked as such complies with the European safety/EMC regulations
C-Tick	Compliance mark	Equipment marked as such complies with the Australian EMC regulations
CPU	Central Processing Unit	The heart of a microprocessor or computer
CS	Chip Select	A connection that is asserted under certain circumstances to select a particular device
DAC	Digital to Analogue Converter	A device for generating an analogue representation of a digital control signal
DIP	Dual In-line Package	A device package format with 2 parallel rows of pins
EL	Electroluminescent	A type of backlight that uses high voltage
EPROM	Erasable Programmable Read Only Memory	A type of memory that is not intended to be re-programmed in circuit
FLASH	Flash RAM	A type of memory very much like EPROM but which is designed to be re-programmed in-system enabling program updates
GAL	Generic Array Logic	A logic device that can be programmed to perform many logic functions
\$	Hexadecimal number	The number \$A is 10 <sub>(decimal)</sub> and \$F is 15 <sub>(decimal)</sub>
IRQ	Interrupt Request	A connection that is asserted when a device has information ready to be accessed by the CPU
Jumper	Shunt, Link	A jumper is used to configure a system by shorting a pair of pins together
LED	Light Emitting Diode	A diode that is optimised to radiate light
LCD	Liquid Crystal Display	A type of display that uses a liquid to prevent the transmission of light
NMI	Non-Maskable Interrupt	An IRQ that cannot be ignored

PSU	Power Supply Unit	The power supply converts incoming mains to voltages usable by the electronics
PWM	Pulse Width Modulation	A cyclic technique of digital power control where a load is switched fully on for a period of time dependant upon the required output power
RAM	Random Access Memory	Memory in which the data contained within can be accessed in any order. The term RAM generally refers to memory that can be read and written to by the system
ROM	Read Only Memory	Memory that cannot be changed by the system
SMD	Surface Mount Device	A miniaturised leadless component mounted on the upper or lower surface of a circuit board
SRAM	Static RAM	A form of RAM that uses static memory cells to store information.

# Appendix A: History of Modifications

Serial Number	Modification

# Appendix B: Connector Pinouts

## Front Panel Card Bus Connector (View from component side)

Palette, Assign, Master Cards

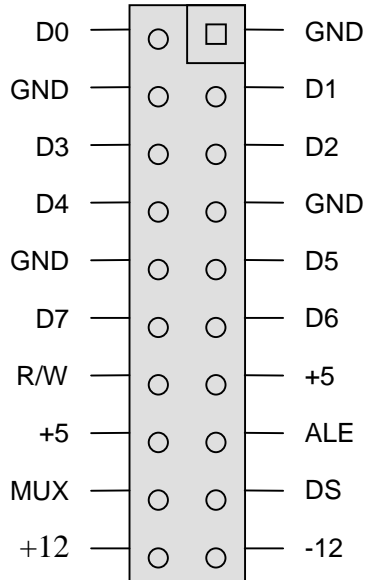

## FDD Power Connector

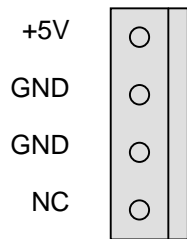

## Main Power Connector (CONN8)

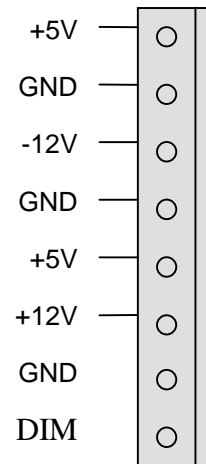

FDD Connector (CONN6)

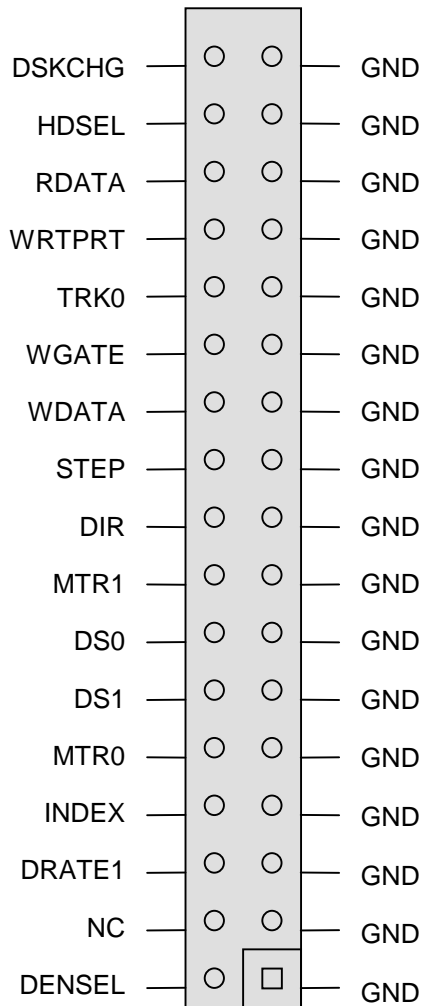

Expansion bus Connector (CONN2)

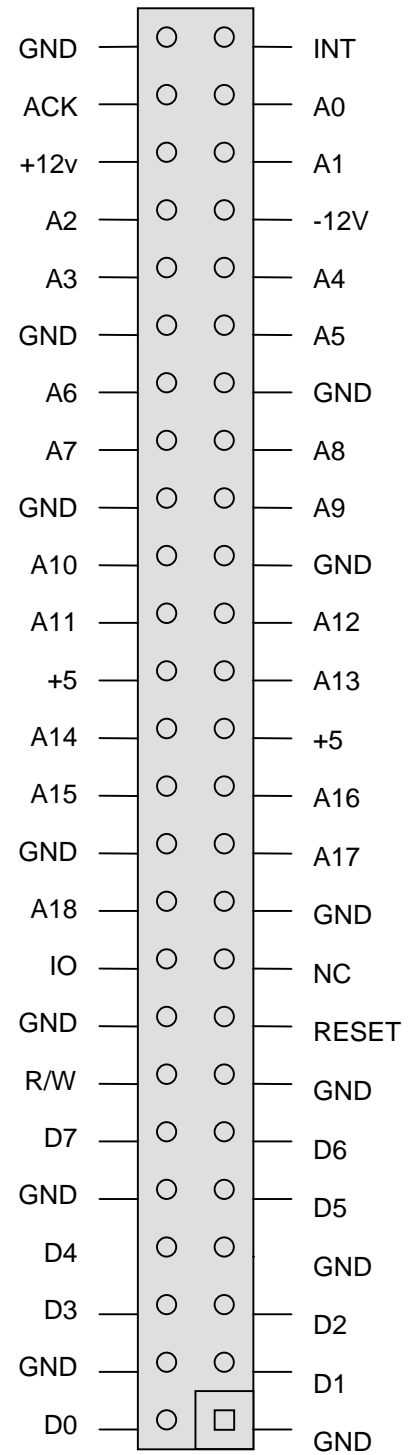

DMX CONNECTOR (Conn19)

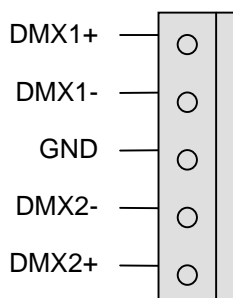

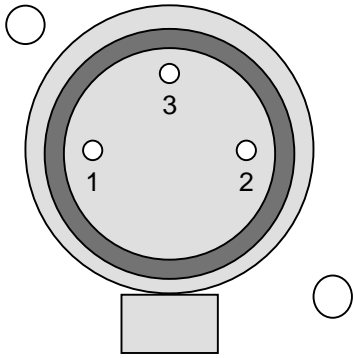

DESK LAMP CONNECTOR

DESK LAMP CONNECTIONS	
PIN No.	FUNCTION
1	NC
2	GND
3	V+

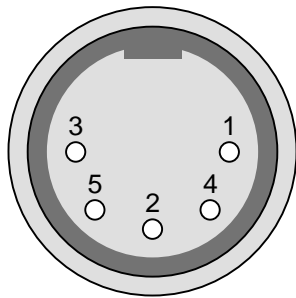

MIDI CONNECTOR

MIDI CONNECTIONS			
PIN No.	FUNCTION		
	IN	OUT	THRU
1	NC	NC	NC
2	NC	SHIELD	SHIELD
3	NC	NC	NC
4	IN+	OUT+	OUT+
5	IN-	OUT-	OUT-

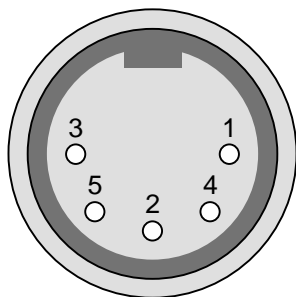

KEYBOARD CONNECTOR

KEYBOARD CONNECTIONS	
PIN No.	FUNCTION
1	KCLK
2	KDATA
3	NC
4	GND
5	+5V

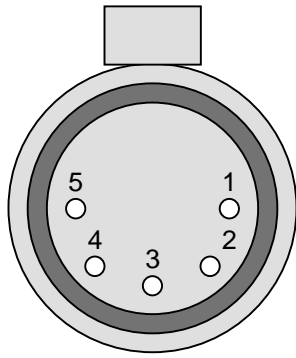

DMX CONNECTOR

DMX CONNECTIONS	
PIN No.	FUNCTION
1	SHIELD
2	SIGNAL-
3	SIGNAL+
4	NC
5	NC

VGA CONNECTIONS	
PIN No.	FUNCTION
1	RED
2	GREEN
3	BLUE
4	NC
5	NC
6	RED RETURN
7	GREEN RETURN
8	BLUE RETURN
9	NC
10	GND
11	NC
12	NC
13	HSYNC
14	VSYSN
15	NC

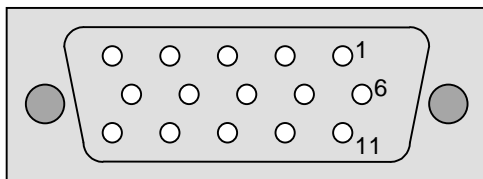

VGA CONNECTOR

# Appendix C: Spare Parts

The following spare parts for Event 4 consoles are available from the JANDS Service Department:

ITEM	PART No.
Switching power supply NFS40-7608	ZSX0200
Fuse M205 2 amp fast blow (mains)	ZEF2150
3.5" Disk drive	ZZA1440
Desklamp socket AXR-3-31PB	ZPG0380
DMX out socket AXR-5-21PB	ZPG2100
Fader 10K 60mm (Alps)	ZRS0200
Fader knob black/white line	ZZK0400
Fader knob black/blue line	ZZK0450
Fader knob black/green line	ZZK0460
Fader knob black/red line	ZZK0470
Fader knob black/grey line	ZZK0480
Encoder HRPB	ZRP0450
Encoder knob	ZZK1210
Switch (Schadow) SERU	ZSW0450
Switchcap SRKL (Schadow)	ZSC0050
Switch (Cherry) MX1A-A1NW	ZSW1500
Switchcap (Cherry) no LED window	ZSC0500
Switchcap (Cherry) with LED window	ZSC0550
Lithium Battery 6126 CR (CPU)	ZDC0100
75176 / DS3695 (DMX driver)	ZIC1010
IC H11N1	ZIC0170
Small back light driver card complete	YPC177
Preset Card complete	YPC173
Palette card complete	YPC172

---

Assign card complete	YPC175
Master card complete	YPC176
CPU card complete	YPC174

## Appendix D: DMX to MIDI adaptor

A DMX to MIDI adaptor cable is required to run some of the Auxiliary tests contained in the Boot ROM. The adaptor should be wired as shown:

DMX pin	MIDI pin	Detail
3	5	connect with 220R 0.25W 5% resistor
2	4	direct connection
1	2	direct connection

## Appendix E: 2 x DMX, MIDI signal combiner

A DMX /MIDI combiner circuit is required to run some of the Auxiliary tests contained in the Boot ROM.

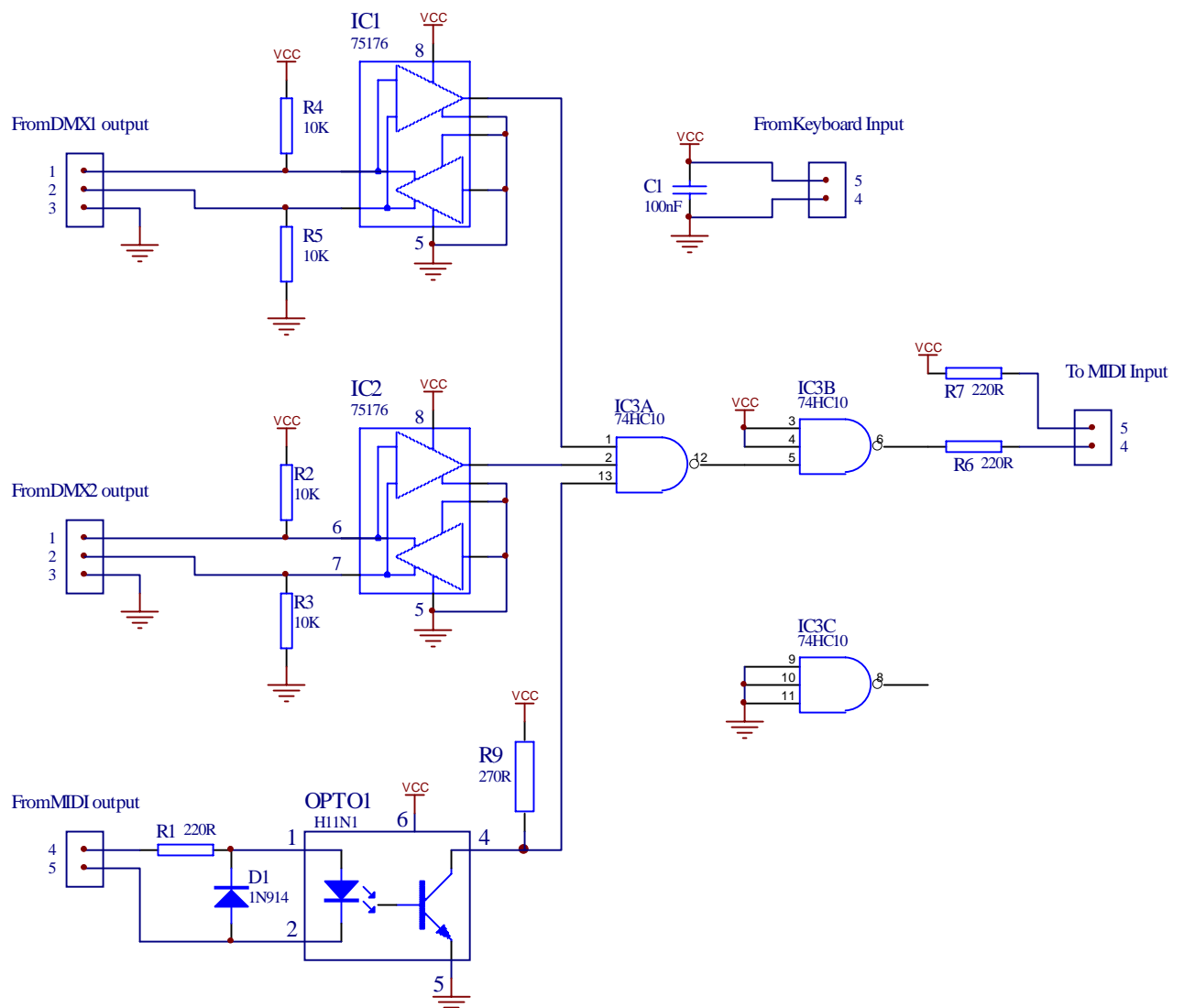

---

# Appendix F: Circuit diagrams

---

# EV4CPU1 Circuit diagrams

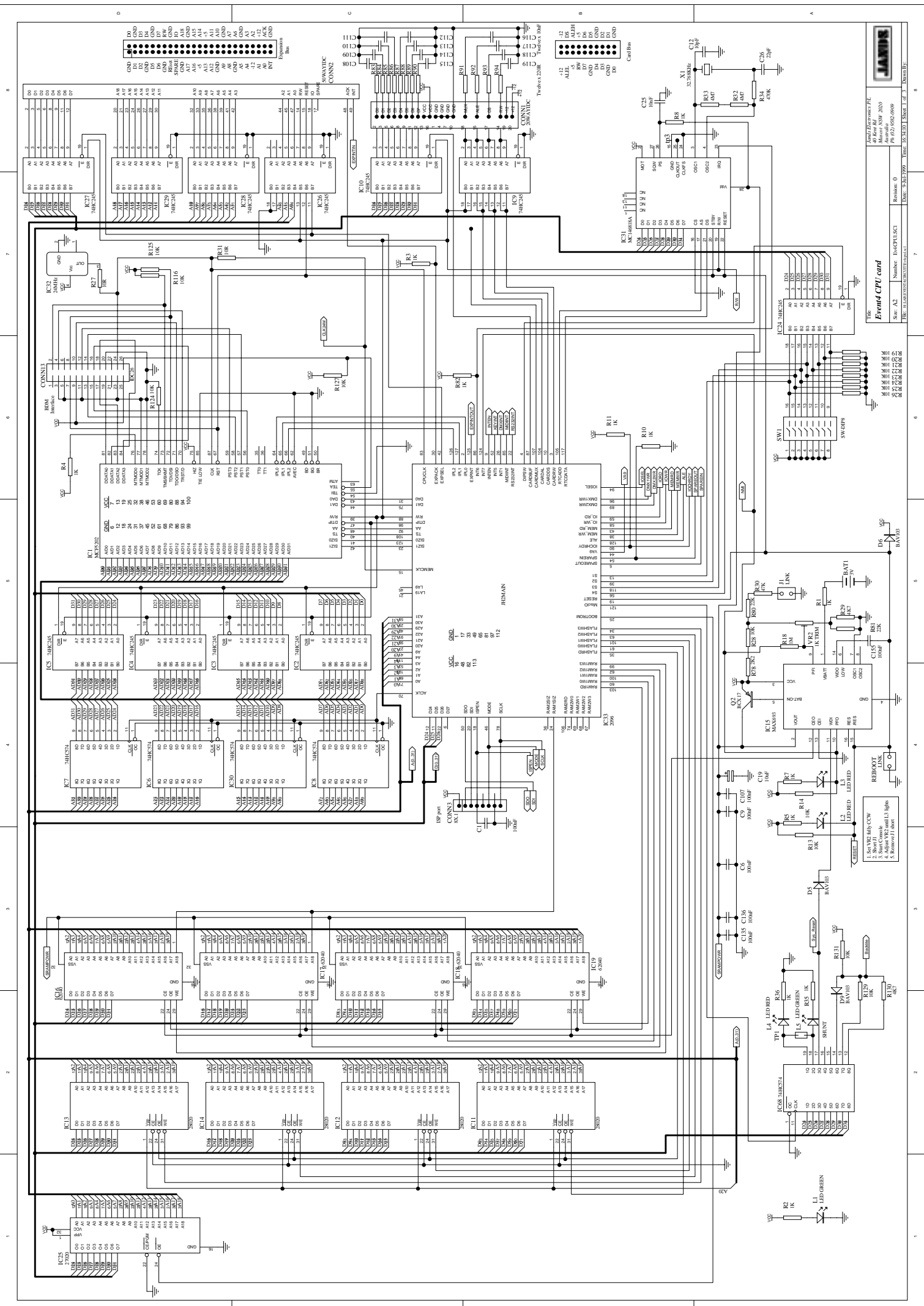

JANSI  
 Janshi Electronics Pte.  
 40, Janshi Rd.  
 Singapore 107661  
 Tel: +65 6339 8888  
 Fax: +65 6339 8889  
 Email: sales@jansi.com.sg  
 Website: www.jansi.com.sg

**Event4 CPU card**  
 Rev: 1.0  
 S/N: A2  
 Date: 2010-03-10  
 Author: JANSI

Rev: 1.0  
 S/N: A2  
 Date: 2010-03-10  
 Author: JANSI

Rev: 1.0  
 S/N: A2  
 Date: 2010-03-10  
 Author: JANSI

Rev: 1.0  
 S/N: A2  
 Date: 2010-03-10  
 Author: JANSI

Rev: 1.0  
 S/N: A2  
 Date: 2010-03-10  
 Author: JANSI

Rev: 1.0  
 S/N: A2  
 Date: 2010-03-10  
 Author: JANSI

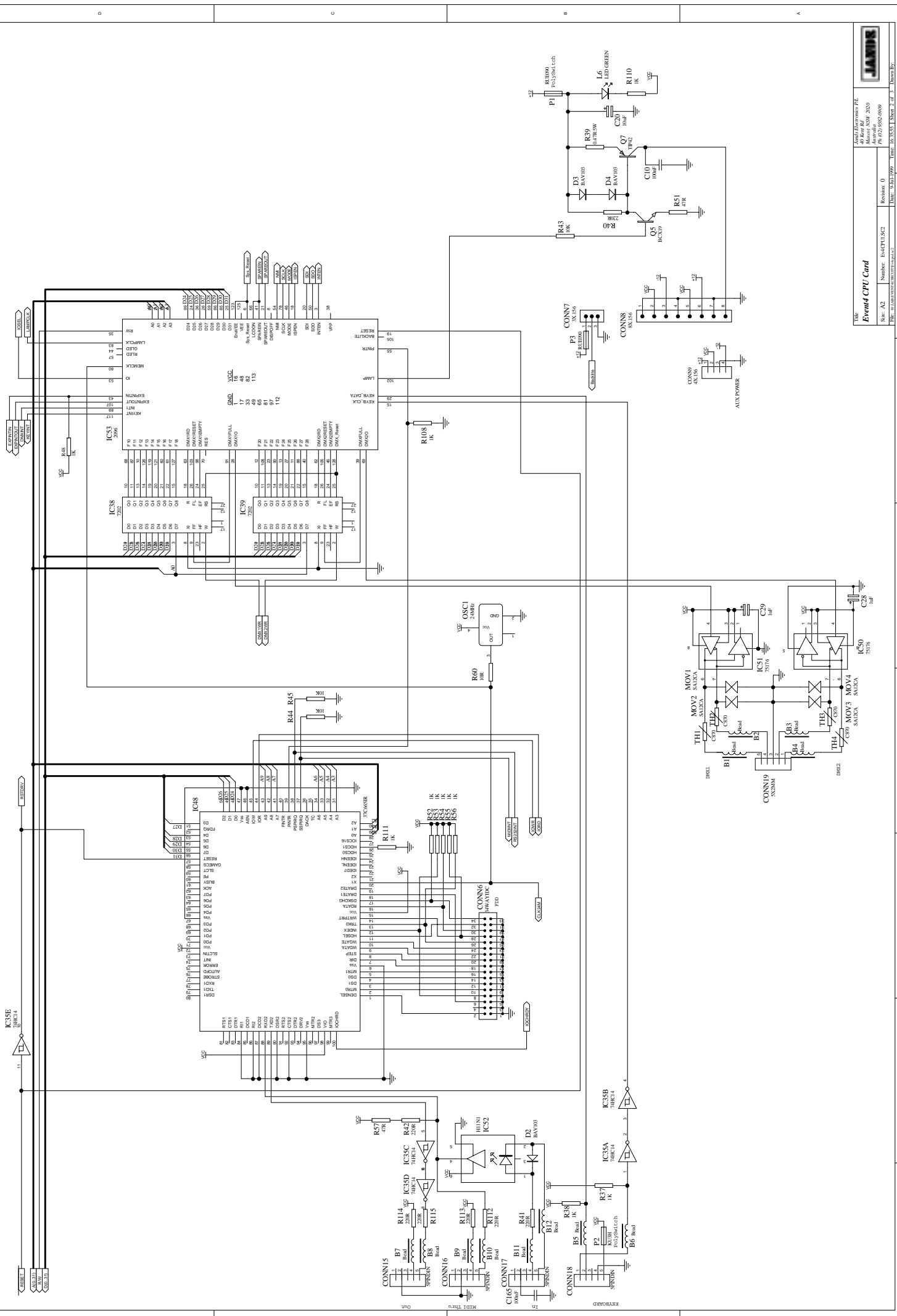



---

# EV4MAST3 Circuit diagrams

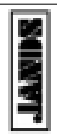
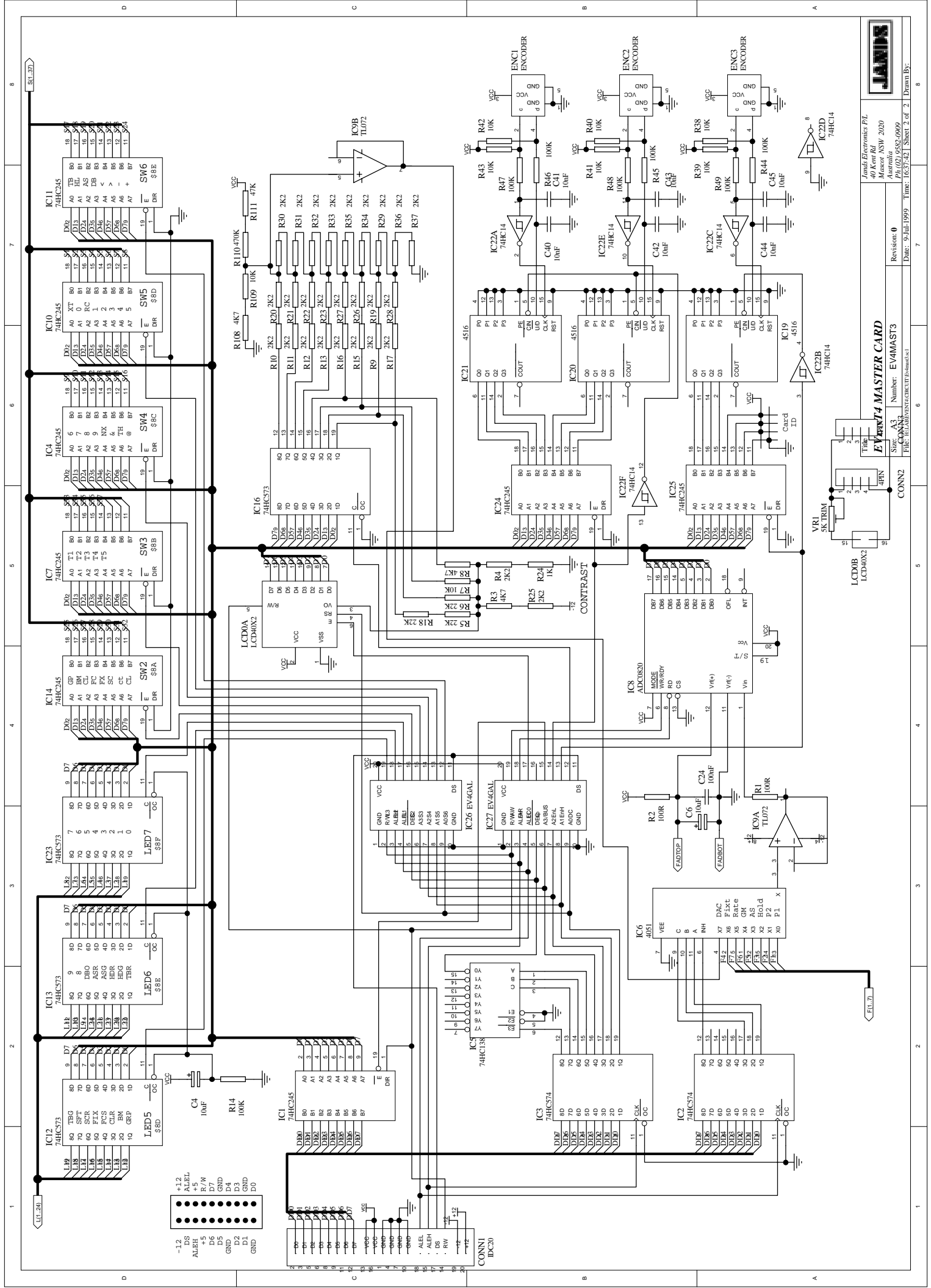

Jaluk Electronics P/L  
 1/8 Kombar NSW 2020  
 Australia  
 Ph: (02) 9592 0009  
 Date: 9-Jul-1999 Time: 16:37:42 Sheet: 2 of 2 Drawn By:

Revision: 0  
 Size: CONN1  
 Date: 9-Jul-1999 Time: 16:37:42 Sheet: 2 of 2 Drawn By:

EV4M74 MASTER CARD  
 Number: EV4M74  
 Size: CONN1  
 Date: 9-Jul-1999 Time: 16:37:42 Sheet: 2 of 2 Drawn By:

EV4M74 MASTER CARD  
 Number: EV4M74  
 Size: CONN1  
 Date: 9-Jul-1999 Time: 16:37:42 Sheet: 2 of 2 Drawn By:

EV4M74 MASTER CARD  
 Number: EV4M74  
 Size: CONN1  
 Date: 9-Jul-1999 Time: 16:37:42 Sheet: 2 of 2 Drawn By:

EV4M74 MASTER CARD  
 Number: EV4M74  
 Size: CONN1  
 Date: 9-Jul-1999 Time: 16:37:42 Sheet: 2 of 2 Drawn By:

EV4M74 MASTER CARD  
 Number: EV4M74  
 Size: CONN1  
 Date: 9-Jul-1999 Time: 16:37:42 Sheet: 2 of 2 Drawn By:

EV4M74 MASTER CARD  
 Number: EV4M74  
 Size: CONN1  
 Date: 9-Jul-1999 Time: 16:37:42 Sheet: 2 of 2 Drawn By:

EV4M74 MASTER CARD  
 Number: EV4M74  
 Size: CONN1  
 Date: 9-Jul-1999 Time: 16:37:42 Sheet: 2 of 2 Drawn By:

EV4M74 MASTER CARD  
 Number: EV4M74  
 Size: CONN1  
 Date: 9-Jul-1999 Time: 16:37:42 Sheet: 2 of 2 Drawn By:

EV4M74 MASTER CARD  
 Number: EV4M74  
 Size: CONN1  
 Date: 9-Jul-1999 Time: 16:37:42 Sheet: 2 of 2 Drawn By:

EV4M74 MASTER CARD  
 Number: EV4M74  
 Size: CONN1  
 Date: 9-Jul-1999 Time: 16:37:42 Sheet: 2 of 2 Drawn By:

EV4M74 MASTER CARD  
 Number: EV4M74  
 Size: CONN1  
 Date: 9-Jul-1999 Time: 16:37:42 Sheet: 2 of 2 Drawn By:

EV4M74 MASTER CARD  
 Number: EV4M74  
 Size: CONN1  
 Date: 9-Jul-1999 Time: 16:37:42 Sheet: 2 of 2 Drawn By:

EV4M74 MASTER CARD  
 Number: EV4M74  
 Size: CONN1  
 Date: 9-Jul-1999 Time: 16:37:42 Sheet: 2 of 2 Drawn By:

EV4M74 MASTER CARD  
 Number: EV4M74  
 Size: CONN1  
 Date: 9-Jul-1999 Time: 16:37:42 Sheet: 2 of 2 Drawn By:

EV4M74 MASTER CARD  
 Number: EV4M74  
 Size: CONN1  
 Date: 9-Jul-1999 Time: 16:37:42 Sheet: 2 of 2 Drawn By:

EV4M74 MASTER CARD  
 Number: EV4M74  
 Size: CONN1  
 Date: 9-Jul-1999 Time: 16:37:42 Sheet: 2 of 2 Drawn By:

EV4M74 MASTER CARD  
 Number: EV4M74  
 Size: CONN1  
 Date: 9-Jul-1999 Time: 16:37:42 Sheet: 2 of 2 Drawn By:

EV4M74 MASTER CARD  
 Number: EV4M74  
 Size: CONN1  
 Date: 9-Jul-1999 Time: 16:37:42 Sheet: 2 of 2 Drawn By:

EV4M74 MASTER CARD  
 Number: EV4M74  
 Size: CONN1  
 Date: 9-Jul-1999 Time: 16:37:42 Sheet: 2 of 2 Drawn By:

EV4M74 MASTER CARD  
 Number: EV4M74  
 Size: CONN1  
 Date: 9-Jul-1999 Time: 16:37:42 Sheet: 2 of 2 Drawn By:



---

# EV4ASN3 Circuit diagrams

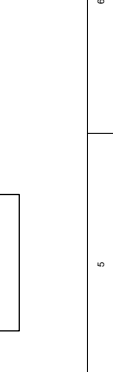
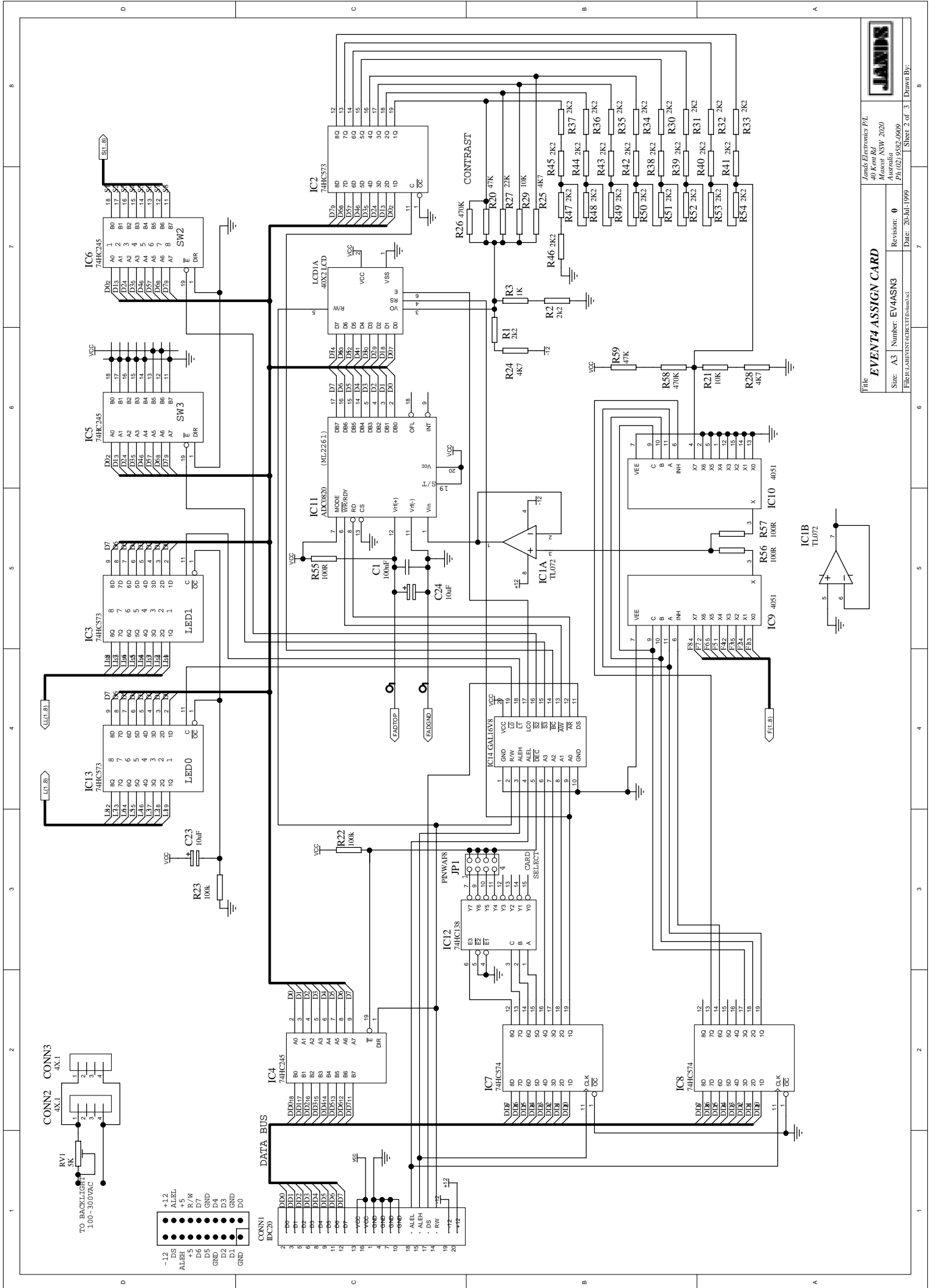

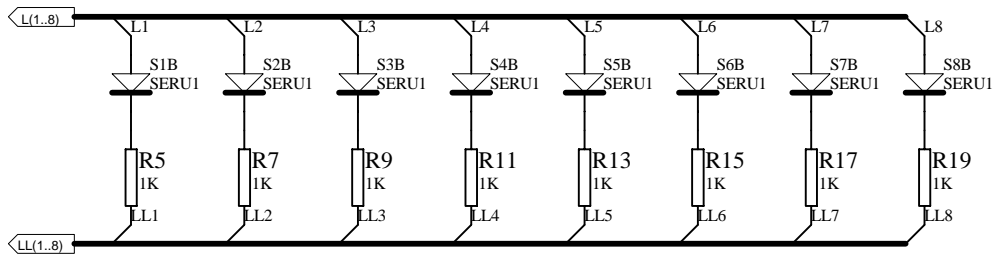
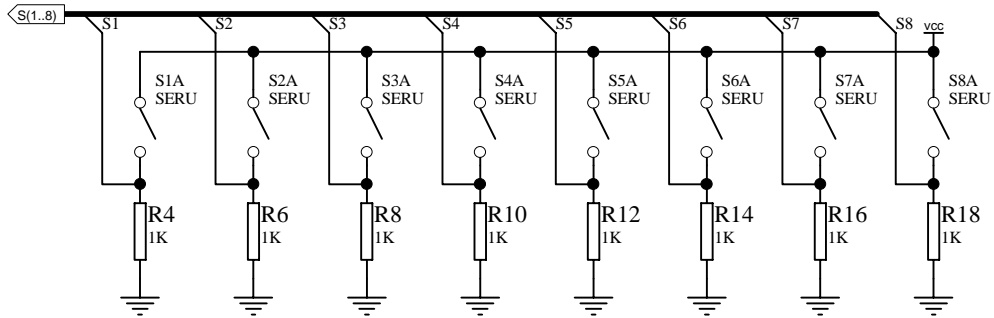
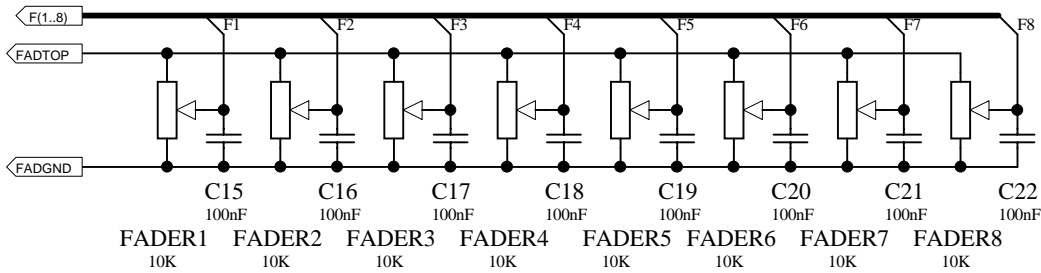
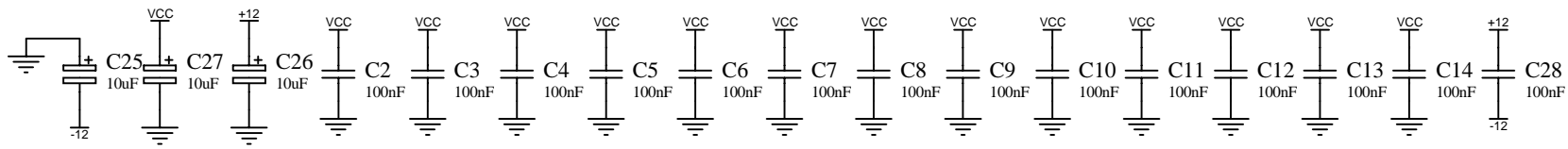

Title		Jands Electronics P/L 40 Kent Rd Mascot NSW 2020 Australia Ph (02) 9582-0909	
<b>EVENT4 ASSIGN CARD</b>			
Size: A4	Number: EV4ASN3	Revision0	
File: H:\LAB\EVENT4\CIRCUIT\Ev4asn3.sc2		Date: 9-Jul-1999	Sheet 3 of 3 Drawn By:



---

# EV4PRE3 Circuit diagrams

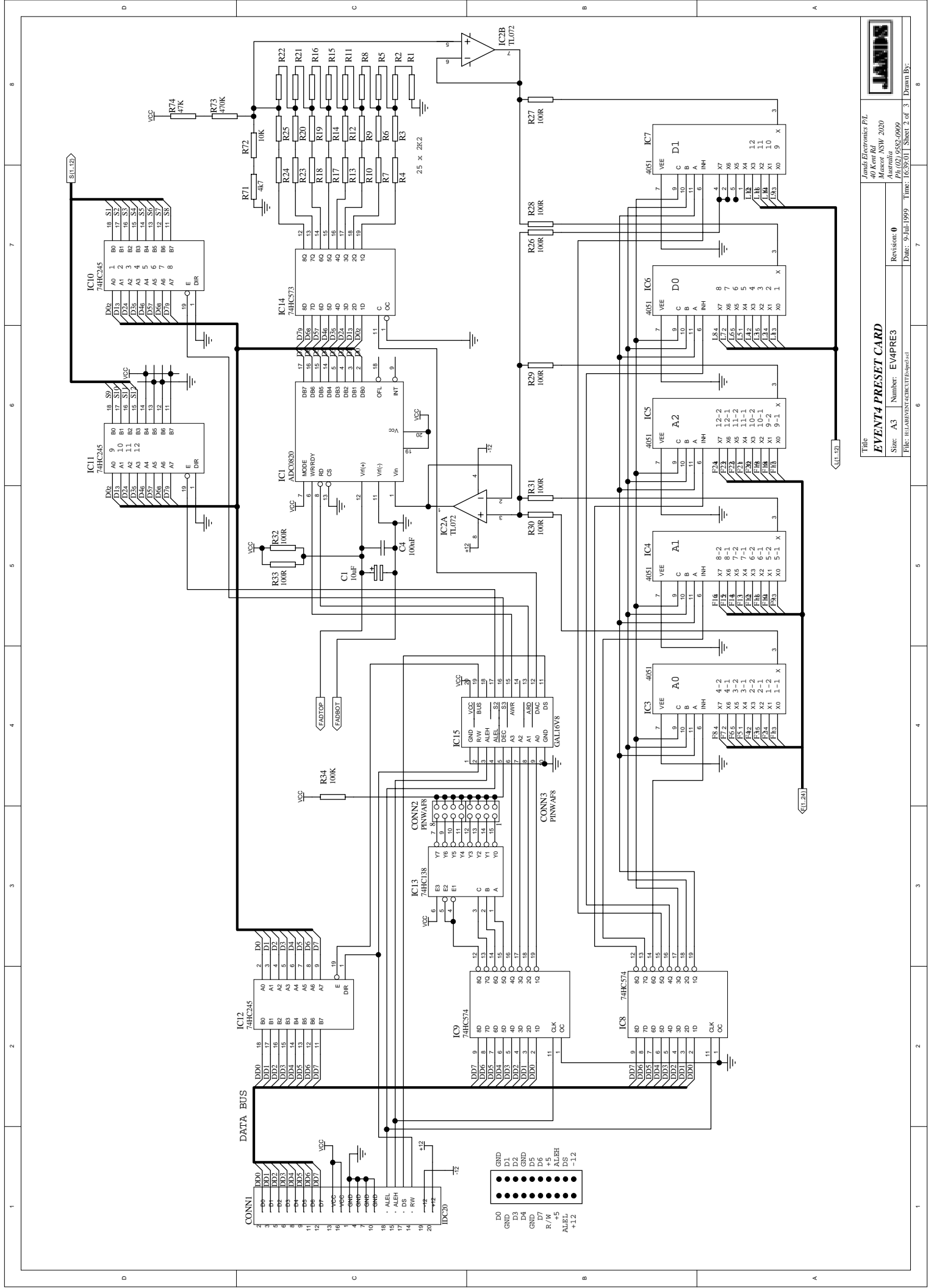

James Electronics P/L  
 17/8 Condamine NSW 2020  
 Australia  
 Ph: (02) 9582 0099

Title  
**EVENT4 PRESET CARD**

Size: A3 Number: EV4PRE3  
 File: H:\ALM\EVENT4\IC15\Bipreset.dwg

Revision: 0  
 Date: 9-Jul-1999 Time: 16:39:01 Sheet 2 of 3 Drawn By:

1 2 3 4 5 6 7 8

A B C D

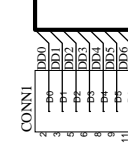
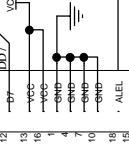
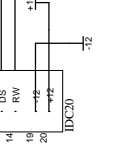
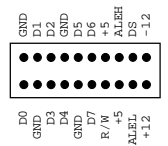

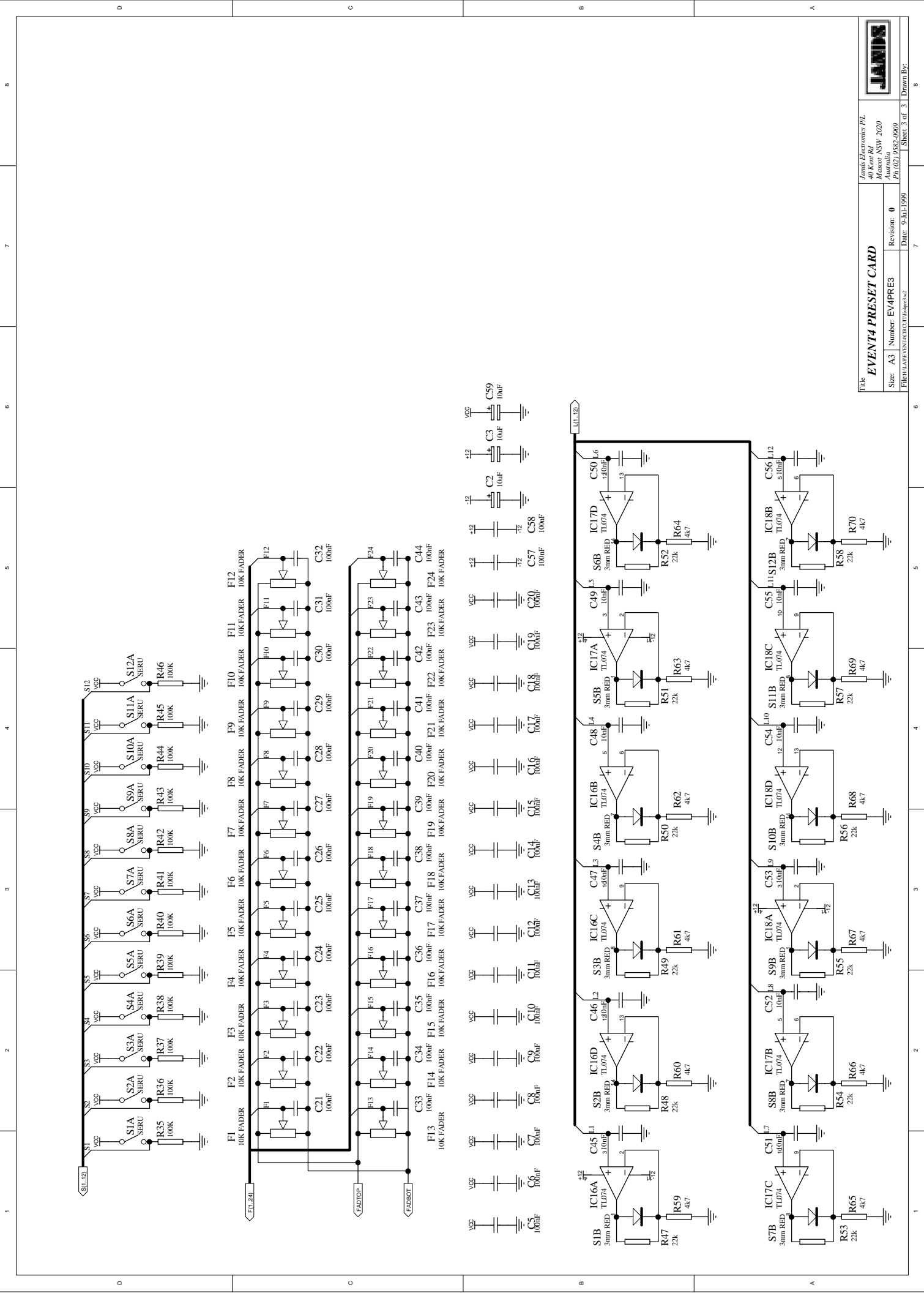

---

# EV4PAL3 Circuit diagrams



---

# BKLTSM2 Circuit diagrams

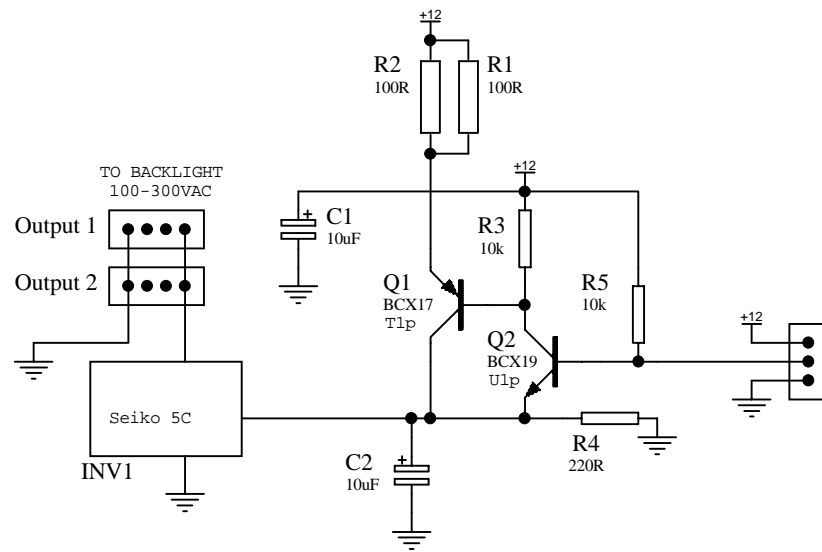

Title		Jands Electronics P/L 40 Kent Rd Mascot NSW 2020 Australia Ph (02) 9582-0909	
<b>Small Backlight driver</b>			
Size: A4	Number: bkltsm10	Revision: 0	
File: H:\LAB\EVENT4\CIRCUIT\Bkltsm12.sch	Date: 9-Jul-1999	Sheet 1 of 1	Drawn By:



1

2

3

4

1

2

3

4