

Performance Racks

19" ENCLOSED EQUIPMENT RACKS FOR FIXED INSTALLATIONS



DESCRIPTION

The Jands Performance range of rugged 19 inch (483mm) equipment racks are ideal for use in permanent installations, especially where cost effectiveness is a major consideration.

FEATURES

- * Rack chassis and strips constructed from 1.2mm zinc seal sheets
- * Sheets are punched and folded under computer control for complete accuracy
- * Supplied in a modular form for easy on-site handling and efficient transport and storage
- * Can be assembled by a single person with a spanner and screwdriver
- * Finished in a durable and attractive gannet (matt grey) powdercoat finish specifically formulated for this application
- * Universal rack mount
- * Two (2) cage-nut strips for accessory mounting

OVERALL SPECIFICATIONS

Material: Chassis - 1.2mm zinc seal steel
 Strips - 1.6mm zinc seal steel

Finish: Durable gannet powdercoat paint

Dimensions:

TYPE	EXTERNAL(mm)	INTERNAL(mm)
• 21 RU	1036(H)×600(W)×500(D)	936(H)×485(W)×400(D)
• 39 RU	1837(H)×600(W)×500(D)	1737(H)×485(W)×400(D)

Net/shipping weight:

TYPE	NET(kg)	SHIPPING(kg)
• 21 RU	27.6	31.5
• 39 RU	40.7	46.6

ORDERING INFORMATION

TYPE	PART No.
• 21 RU performance range rack	JND-1609
• 39 RU performance range rack	JND-1610
• M6 cage nuts #6 (per 50)	JND-1557
• M6 × 16mm black pozi drive head bolts (per 50)	JND-1559
• M6 black nylon flat washers (per 100)	JND-1550
• M6 black steel washers (per 100)	JND-1551
• Professional rack mounting bolts (pack of 100)	JND-1560

Comprises: - M6 × 20mm stainless steel button head Allen bolts
 - M6 stainless steel and M6 white nylon flat washers

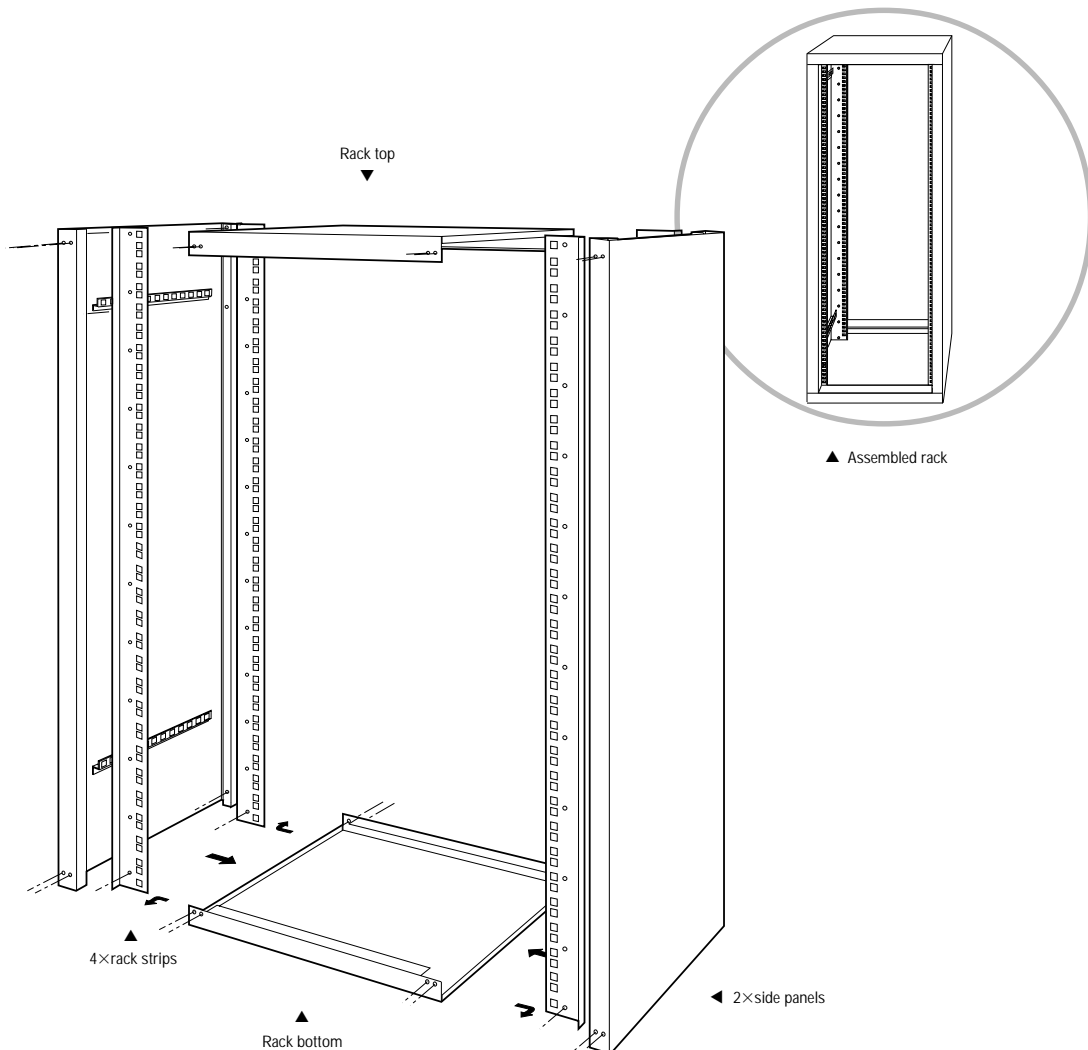

Performance rack

19" ENCLOSED EQUIPMENT RACKS FOR FIXED INSTALLATIONS

Performance Racks

Performance Racks

19" ENCLOSED EQUIPMENT RACKS FOR FIXED INSTALLATIONS



ARCHITECTS AND ENGINEERS SPECIFICATION

The rack chassis shall be constructed from 1.2mm zinc seal sheets and the rack strips from 1.6mm zinc seal sheets. The sheets are to be punched and folded under computer control for complete accuracy. The rack is to be finished in a durable gannet (matt grey) powdercoat finish specifically formulated for this application.

Sizes of the rack are to be as follows:

External height 1036mm (21RU); 1837mm (39RU)
External width 600mm (all types)

External depth 500mm (all types)
Internal height 936mm (21RU); 1737mm (39RU)
Internal width 19"/483mm standard (all types)
Internal depth 400mm (all types) (internal depth measurement from the front of the front rail to the rear of the rear rail)

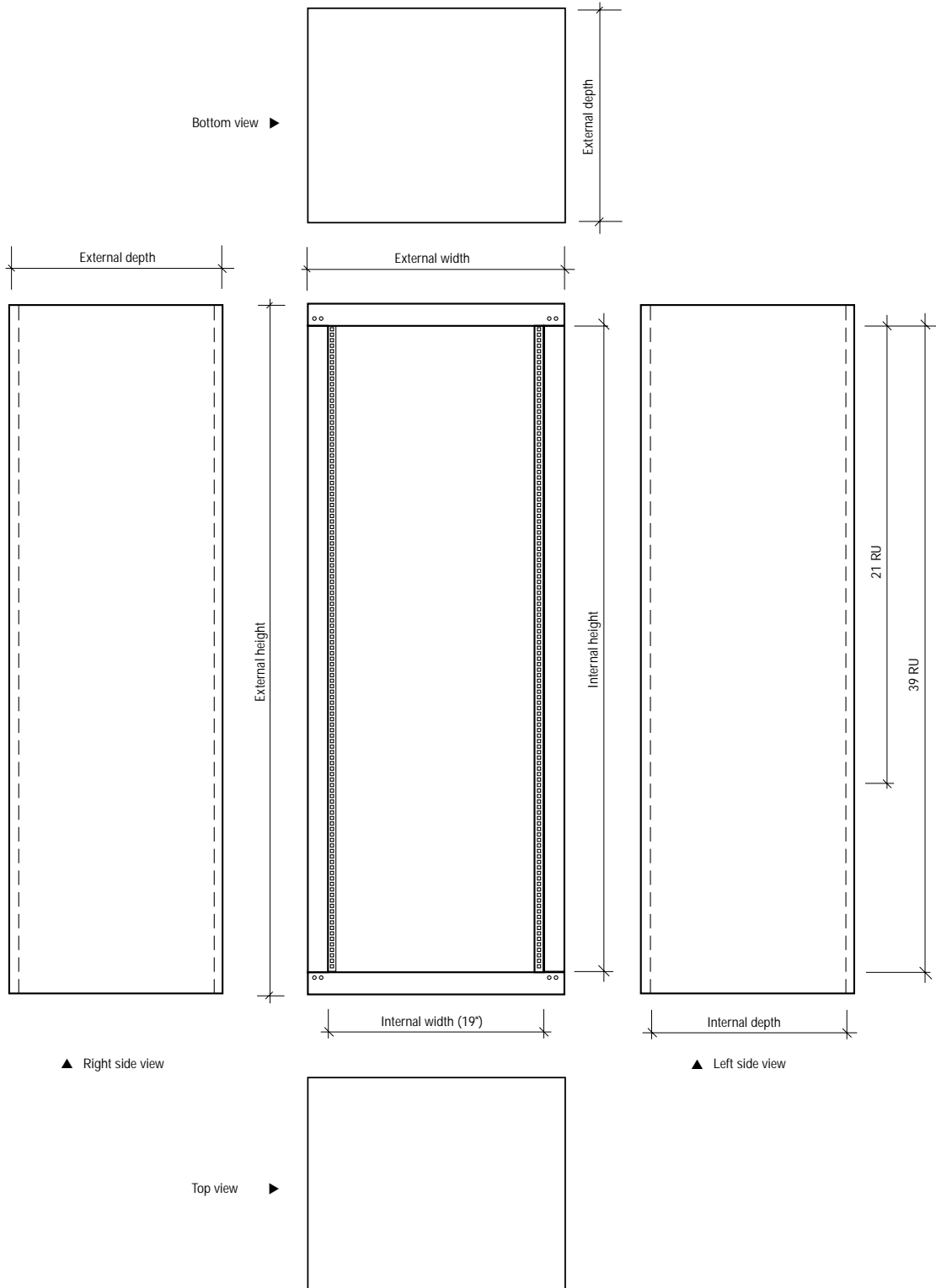

19" ENCLOSED EQUIPMENT RACKS FOR FIXED INSTALLATIONS

Performance Racks