

FP12WM

12 CHANNEL 2.4 kVA WALL MOUNTING DIMMER RACK



DESCRIPTION

The Jands FP12WM is a wall mounting high quality, rugged, 12 channel 2.4 kVA per channel dimmer rack specifically designed for contracting / theatre applications.

A separate wall bracket simplifies the installation process. It allows cabling to be routed to the dimmer location prior to the installation of the actual dimmer units, providing the contractor with the ability to fit off the dimmers when the site is secure.

As an option, a 24 way patch panel kit is available which, when combined with the extended wall mounting bracket, provides the end user with an economical and compact combined dimmer rack/patch system.

FEATURES

- * 12 × 2.4 kW dimming channels
- * DMX-512 digital control protocol
- * DMX-512 terminating switch
- * Suitable for permanent installations
- * Soft turn on characteristic
- * Low acoustic / electrical noise
- * Toroidal chokes
- * Three mains phase indicator LEDs
- * "DMX-IN" LED for DMX-512 signal indication
- * "STATUS" LED for dimmer status indication
- * Two DMX-bank select switches
- * Built-in test facilities
- * Dimmer curve set for linear relationship between the control input and output power
- * Compensates for fluctuations in the mains supply voltage and minimises the effect of superimposed control tones, ensuring a constant light output and increased lamp life
- * May be rack mounted, attached to a wall by means of the supplied mounting brackets or flown using hook clamps
- * Microprocessor control
- * Built-in captive nuts for rigged applications
- * Single or three phase operation
- * Over-temperature cutout
- * Pre-heat facility
- * Dimmer will hold last DMX value should control data be interrupted



OVERALL SPECIFICATIONS

Channels:	12
Power rating:	2.4 kVA (10A/240V) per channel
Power supply type:	3-phase, 240V phase-to-neutral (415V phase-to-phase) with neutral and earth
Power requirements:	3-phase 240 VAC / 50 Hz, 40 A/phase max, full size (40 A) neutral required plus earth
Current:	40 Amps per phase (max.)
Dissipation:	<1% of output load (288W max.)
Dimmer curve:	Linear power
Max. ambient operating temp:	40°C
Control input:	DMX-512/1990 protocol
Output connectors:	1 × Australian 3-pin 10 Amp outlet per channel (export models may vary)
Output risetime:	> 130 μs (10%~90%)
Output protection:	12 × 10A thermal/magnetic circuit breakers
Test facility:	12-way channel selection using DMX select switches

Dimensions: 482mm(W)×158mm(D)×485mm(H) (with wall mounting bracket)

Net/shipping weight: 23kg

SUPPLIED ACCESSORIES

- 1 × wall/rack mounting bracket
- 1 × operating manual

ORDERING INFORMATION

MODEL/PART	PART NO.
• FP12WM with 12 × 10 Amp Australian outlets	JND-FP12WM-A
• FP12WM with 12 × hard wired outputs	JND-FP12WM-H
• Extended wall mounting bracket	JND-WM-EBP
• Patch kit (Refer to the Technical Specification Sheet of WM-Patch)	
• 40 Amp flexible lead & DMX socket kit (Factory fitted at time of ordering)	JND-WM-FLEX

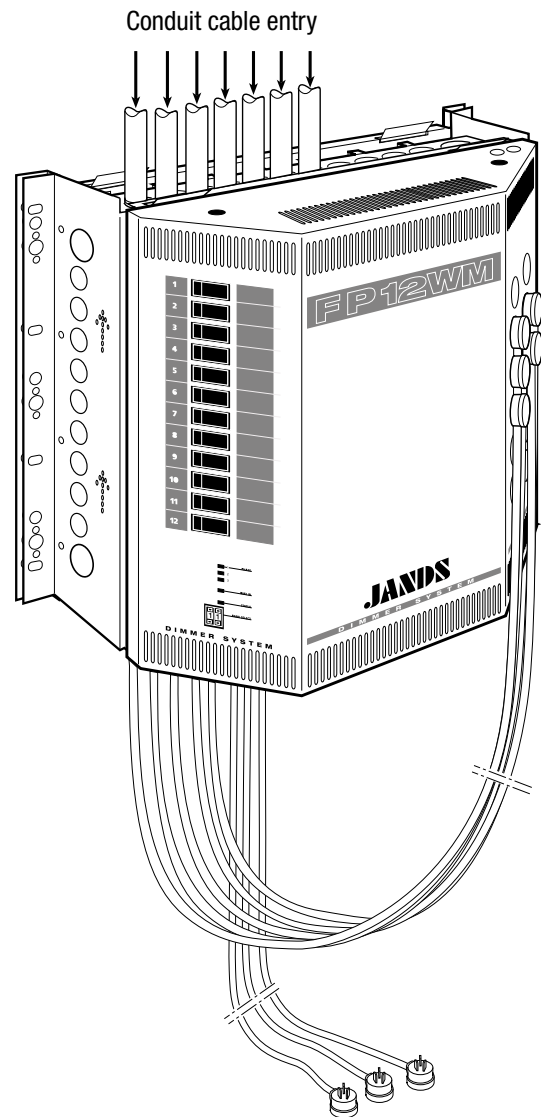

▲ FP12WM dimmer shown with supplied wall/rack mounting bracket and optional extended mounting bracket / patch kit

12 CHANNEL 2.4 kVA WALL MOUNTING DIMMER RACK-

FP12WM

FP12WM

12 CHANNEL 2.4 kVA WALL MOUNTING DIMMER RACK



ARCHITECTS & ENGINEERS SPECIFICATION

Electronics

The dimmer rack shall receive and decode banks of twelve (12) control signals complying with the industry standard USITT DMX-512/1990 protocol.

If the DMX signal is interrupted, the dimmer outputs shall default to the last received DMX frame.

The DMX circuitry shall incorporate an internal DMX Terminate switch to minimise signal reflections on long signal lines.

The dimmer rack shall have a control response time of not more than ten (10) milliseconds, input to output.

The dimmer rack shall utilise two miniature BCD rotary switches to select the DMX bank allocated to that dimmer.

The dimmer rack shall match a control input to power output in a linear relationship. Each of the twelve (12) dimmer channels shall smoothly control loads from 25 watts to 2400 watts.

The dimmer rack shall utilise Toroidal chokes which are acoustically quiet and provide a risetime in excess of 130 microseconds.

The dimmer rack shall be factory tested and cyclically burned-in for a minimum of 24 hours.

Electrical

The dimmer rack shall operate from a three-phase plus neutral and earth supply of 415 volts AC phase-to-phase, and with a nominal supply frequency of 50 Hz (60Hz selectable).

The dimmer rack shall feature twelve (12) identical channels capable of driving 2.4 kW loads. All channel outputs shall be protected by 10 amp thermal-magnetic circuit breakers.

Mechanical

The dimmer rack shall be designed to either mount in a standard 19-inch equipment rack or be permanently attached to a wall with the supplied wall-mounting brackets.

The dimmer rack shall be 440 mm wide × 130 mm deep × 485 mm high. The dimmer rack shall have angled sides to minimise the chassis profile and facilitate ease of patching when installing multiple racks.

The dimmer rack shall be constructed of 1.2 mm steel, and shall be provided with a removable panel for access to internal electronics. All chassis surfaces shall be properly treated and finished in powdercoat or zinc passivating.

The control surface shall be scratch-resistant 0.25 mm Lexan with legends reverse silk-screen printed from behind.

All operator controls and indicators shall be provided on the front face of the dimmer.

The dimmer rack chassis shall be designed to allow for adequate convection cooling, provided the ambient temperature does not exceed 40°C (113°F).

A separate wall mounting bracket shall allow the contractor to install the cabling to the proposed dimmer location, prior to the actual on-site installation of the dimmer unit itself. An optional extended mounting bracket shall

facilitate the installation of the dimmer in situations where the wiring is surface mounted or run in conduits.

The dimmer rack shall easily interlock with the wall brackets by means of a dual tongue-and-slot arrangement to facilitate cable installation.

The dimmer shall be the JANDS FP12WM.

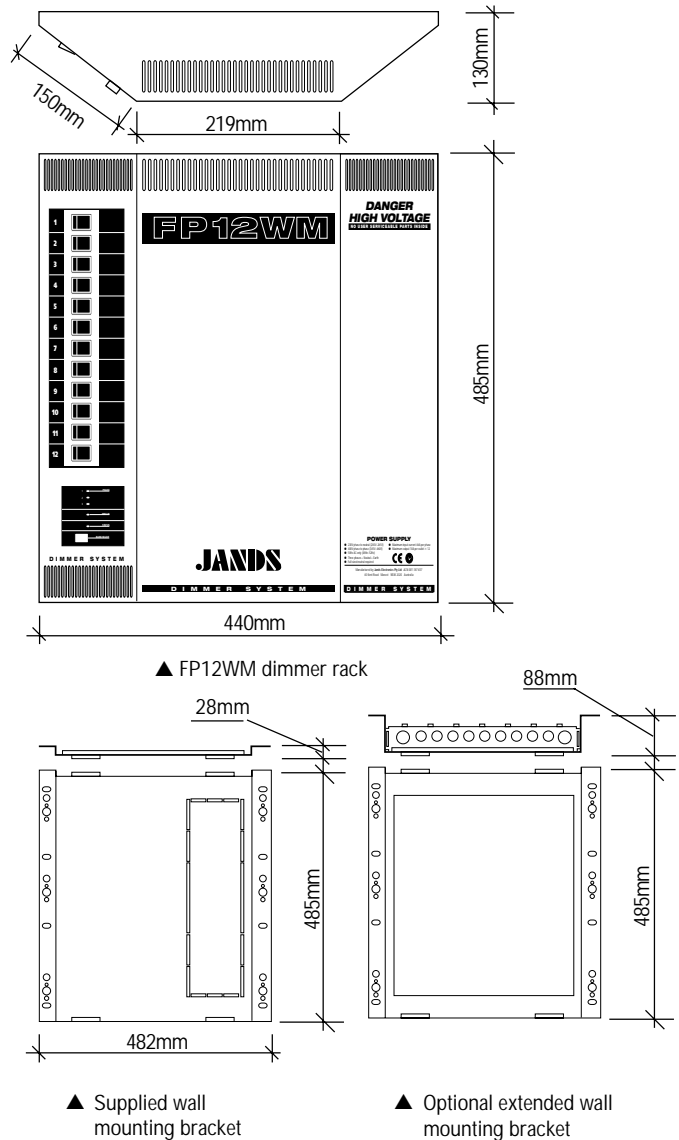

12 CHANNEL 2.4 kVA MOUNTING DIMMER RACK

1 THROUGH WALL CABLE ENTRY

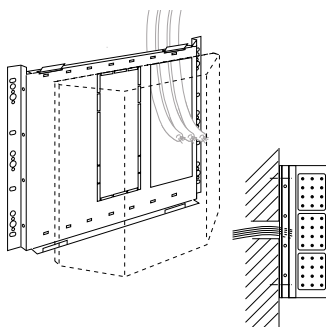

2 SURFACE MOUNTED CONDUIT

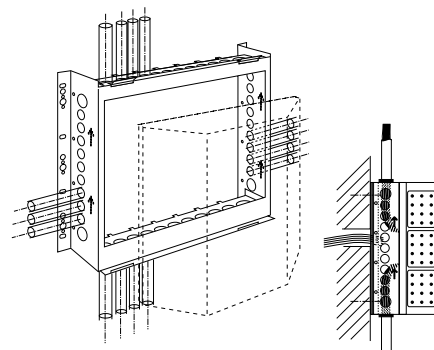

3 CABLE TRAY (shown with top/bottom conduit plates removed)

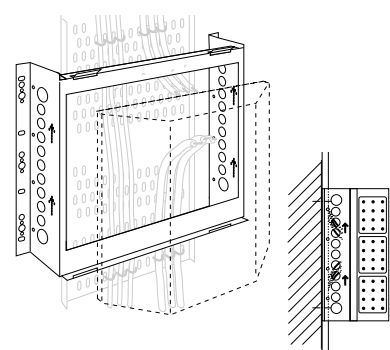

Jands Electronics Pty Ltd 40 Kent Road Mascot NSW 2020 Australia
 Phone: +61 (0)2 9582 0909 Fax: +61 (0)2 9582 0999 Internet: www.jands.com.au

Specifications subject to change without notice. Manufactured by Jands Electronics Pty Ltd ACN 001 187 837.
 Note: While all due care has been taken in the preparation of this document, Jands Electronics shall not be liable for any inaccuracies or omissions which may occur herein.

FP12WM

TSS-FP12WM-0506-05