

DESCRIPTION

The Jands WMXHR is a high quality wall mounting 12 channel dimmer rack designed for contracting/theatre applications where cost effectiveness and ease of use are a priority.

A separate wall bracket simplifies the installation process. It allows cabling to be routed to the dimmer location prior to the installation of the actual dimmer units, providing the contractor with the ability to fit-off the dimmers when the site is secure.

An optional extended wall mounting bracket is available which allows the dimmer to be used with surface mounted cable tray or conduit.

FEATURES

- 12 x 2.4 kW dimming channels
- E1.11 DMX-512 digital control protocol
- DMX-512 terminating switch
- Dimmer will hold last DMX value for 11 minutes if control data is lost
- Three mains phase indicator LEDs
- Microprocessor control
- "DMX-IN" LED for DMX-512 signal indication
- "FAULT" LED for dimmer error condition indication
- Three x 7 segment digital display for DMX start channel and other operating modes
- Built-in test facilities
- Dimmer curve set for linear relationship between the control input and output power
- Soft power-up characteristic
- Pre-heat facility
- Opto-fired Triac output devices
- Toroidal chokes give low acoustic/electrical noise
- Smart current-control software prevents nuisance tripping of circuit breakers
- Compensates for fluctuations in the mains supply voltage and minimises the effect of superimposed control tones, ensuring a constant light output and increased lamp life
- Single internal temperature-controlled DC fan
- Three phase operation
- Over-temperature cut-out
- May be rack mounted or fixed to a wall using the supplied mounting hardware. An optional extended mounting bracket allows mounting over cable tray or surface conduit.
-  CTick compliant

OVERALL SPECIFICATIONS

Channels:	12
Power rating:	2.4 kW (10A/240V) per channel.
Power supply type:	3-phase, 240V phase-to-neutral (415V phase-to-phase) with earth.
Power requirements:	3-phase 240 VAC, 50/60 Hz, 40A per phase max, full size (40A) neutral required plus earth.
Supply current:	40 Amps per phase (max.)
Mains Input Connector:	Screw Terminal

Dissipation:	<1.0% of output load (288W max)
Ambient temperature:	40°C max
Dimmer curve:	Linear power
Output connectors:	1 x 3-pin Australian 10 Amp outlet per channel.
Output risetime:	> 220 µs (10% - 90%)
Output protection:	12 x 10A thermal/magnetic circuit breakers
Control input:	USITT E1.11 DMX-512 protocol
Input connector:	5-pin AXR with loop-through socket and termination switch
Display:	3 x 7 segment, high brightness
Start Channel:	Increment by 12 channel bank
Test facility:	Individual channel on/off Phase/All 0,20,40,60,80,100%
Dimensions:	483mm(19")(W) x 158mm(D) x 485mm (11RU)(H) including wall mounting bracket
Net/shipping weight:	23 / 27 kg

SUPPLIED ACCESSORIES

- Wall/rack mounting bracket
- Operating manual

ORDERING INFORMATION

MODEL/PART	PART NUMBER
• WMX with 12 x 3-pin/10A GPO outlets	JND-WMXHR-A
• WMX hardwired in/out with CB's	JND-WMXHR-H
• Extended wall mounting bracket	JND-WM-EBP
• Flex mains input wiring kit (Includes tail and 40A 5 pin plug)	JND-WMX-FLEX
• Complimentary patching system	Refer WM Patch sheet





12 CHANNEL 2.4 KW WALL MOUNTING DIMMER

ARCHITECT & ENGINEERS SPECIFICATIONS

Electronics

The dimmer rack shall receive and decode banks of twelve (12) control signals complying with the industry standard USITT E1.11 DMX-512 protocol. If the DMX signal is interrupted, the dimmer outputs shall default to the last received DMX packet. If control is not restored within 11 minutes the outputs shall be driven off.

A digital display and miniature switches shall be used to select the DMX start channel and set other operating modes of the dimmer. The start channel shall be able to be selected in steps of 12 channels. The DMX circuitry shall incorporate a DMX Terminate switch to minimise signal reflections on long control lines.

The dimmer rack shall match a control input to power output in a linear relationship. Each of the twelve (12) dimmer channels shall smoothly control loads from 25 watts to 2400 watts. The dimmer rack shall have a control response time of not more than fifty (50) milliseconds, input to output. The dimmer shall incorporate current control algorithms that reduce the instance of circuit breaker nuisance tripping.

The dimmer rack shall utilise toroidal chokes which are acoustically quiet and provide a risetime in excess of 220 microseconds.

For heatsink temperatures above 60°C the temperature controlled fan shall run at full speed. The dimmer shall feature temperature monitoring electronics that will trigger a thermal shut-down mode when the heatsink temperature exceeds 85°C. A hard-wired thermal switch shall disable the dimmer should the heatsink temperature exceed 110°C.

Electrical

The dimmer rack shall operate from a three-phase plus neutral and earth supply of 415 VAC phase-to-phase, with a nominal supply frequency of 50 Hz (60Hz selectable).

The dimmer rack shall feature twelve (12) identical channels capable of driving 2.4 kW loads. All channel outputs shall be protected by 10 Amp thermal/magnetic circuit breakers.

Mechanical

The dimmer shall be designed to mount in a standard 19-inch equipment rack or be permanently attached to a wall with the supplied mounting bracket. The supplied wall-mounting bracket shall allow the contractor to install the cabling to the proposed dimmer location prior to the actual on-site installation of the dimmer itself. An optional extended mounting bracket shall facilitate installation of the dimmer over surface mounted cable trays or conduit.

The dimmer chassis shall be 440mm wide X 158mm deep x 485 mm high, not including mounting bracket. The dimmer shall have angled sides to minimise chassis profile and facilitate ease of patching when installing multiple racks. The dimmer shall be constructed of 1.2 mm steel, and shall be provided with a removable panel for access to internal electronics. All metal surfaces shall be properly treated and finished in powdercoat or zinc plating

The control surface shall be scratch-resistant 0.25 mm polyester with legends reverse silk-screen printed from behind.

The dimmer rack chassis shall be designed to allow for fan cooling, provided the ambient temperature does not exceed 40°C. Adequate ventilation must be provided.

The dimmer shall be the JANDS WMXHR.

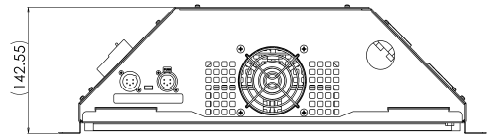
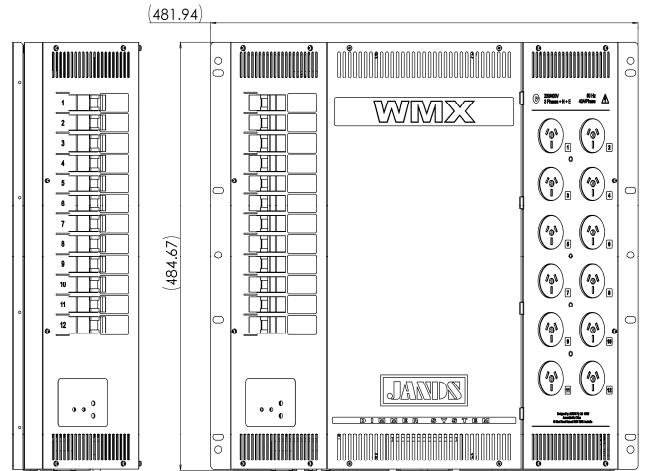

▲ WMX Dimmer including supplied mounting bracket

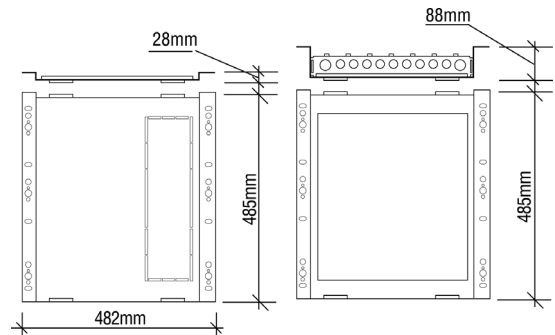

▲ Supplied wall mounting bracket

▲ Optional extended wall mounting bracket

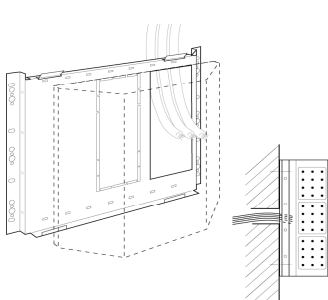

▲ Through wall cable entry

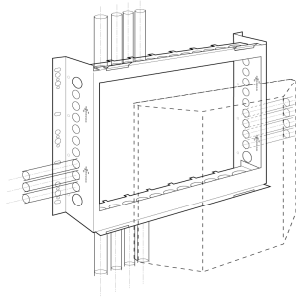

▲ Mounted over surface conduit

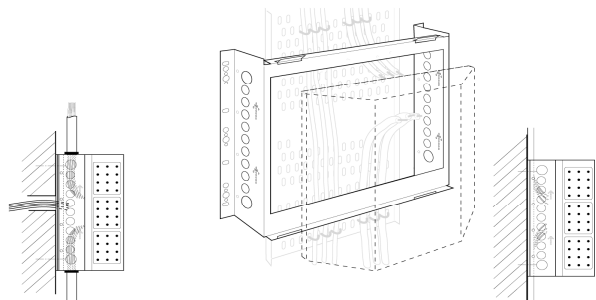

▲ Mounted over cable tray