

DESCRIPTION

The Jands SP650AC-X Standard Motorised Drum Hoist is designed for use in motorised rigging systems and power flying systems in theatres, schools and public halls.

The Rated Capacity of the hoist is 650kg and can accommodate 6 steel wire ropes with a working length of up to 20m.

The maximum lifting speed is 1.2ms^{-1} with a payload of 300kg or less, reducing to a maximum speed of 0.6ms^{-1} with a payload of 650kg.

The minimum lifting speed, under any payload condition, is 0.1ms^{-1} .

A direct coupled, and monitored, 4 pole rotary limit switch provides end-of-travel and emergency over-travel limits in both up and down directions.

A separate full load brake on the drum output, in conjunction with an overspeed detection circuit, ensures full compliance with the requirements of AS1418.1:2002.

A separate hoist control cabinet (supplied with the hoist) connects to the hoist via plugs & sockets for ease of service. This enclosure contains the electronic motor inverter (drive), hoist control card, safety circuits, and connections for an external load cell, slack wire detector and rope crossed-groove detector (mounted on the hoist).

The Jands SP650AC-X hoist is controlled as a stand-alone unit via the Jands SAX-P1 hoist controller (sold separately).

When used in conjunction with this controller, the SP650AC-X features six (6) programmable show presets with both position and speed information, basic up/down control, variable speed and graphical displays of both position and speed information.

Preset information is stored within the hoist control electronics, so a single controller can be used to (individually) control several hoists.

Other models of the SP motorised drum hoist are available for high capacity (1,150kg), high speed (1.6ms^{-1} with 400kg payload) and group control, using either ASM Genesis or Jands group controllers.

The Jands SP650AC-X motorised drum hoist is designed and built to fully comply with the requirements for a serial hoist to AS1418.2-1997. When used in conjunction with a load measuring head pulley (sold separately) the Jands SP650AC-X meets the safety factor, overload and braking requirements of the German safety regulation BGV-C1.

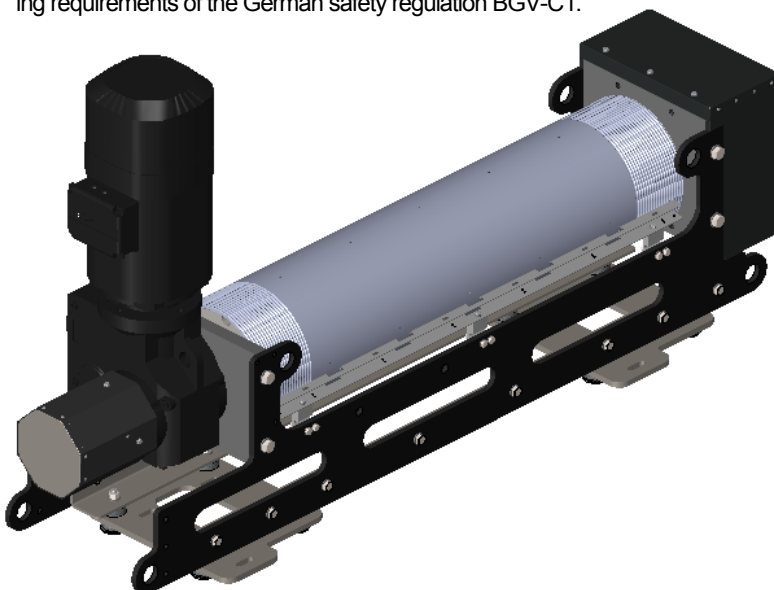

SPECIFICATIONS

Hoist	
Hoist classification	: M5 to AS1418.1-2002
Hoist type	: Motorised grooved drum
Drum diameter	: 265mm (nominal)
Rated Capacity	: 650kg
Motor	: 4kW 4 Pole AC (8-80Hz)
Gearbox	: Helical Bevel, 25.62:1
Brakes	: Failsafe Motor Disc Brake Failsafe Drum Disc Brake
Limit switch	: Rotary, 4 pole, direct coupled
Rated Speeds	
Maximum	: 1.2ms^{-1} (300kg payload)
	: 0.6ms^{-1} (650kg payload)
Minimum	: 0.1ms^{-1} (any payload)
Steel Wire Rope	
Number and length	: 6 x 20m (maximum)
Type	: 6mm, 6x19, galvanised
Minimum grade	: Grade 1570, 17.6kN MBF
Control Enclosure	
Supply	: 230/400V, 50Hz, 3PNE, 10.7A
Supply Connector	: 20A 5Pin 3 phase cord plug
Output	: 3 x 230V400V, 8-80Hz, 11.9A
Control Type	: Open loop electronic inverter
Dimensions	
Dimensions (mm)	: 376(W) x 1920(L) x 1005(H)
Weight	: 380kg

FEATURES

- 650kg lifting capacity at 0.6ms^{-1}
- 1.2ms^{-1} maximum speed at 300kg payload
- 0.1ms^{-1} minimum speed
- 6 x ropes with up to 20m lifting height (drift)
- 6 x position/speed presets (via SAX-P1 controller)
- Separate control enclosure (included) requires only a 3 phase power supply and a Cat5 control cable
- Full load output brake and over speed brake control
- Redundant upper and lower hard limit switches
- 'Soft' upper and lower limits for controlled deceleration
- Cross-wire and slack wire detectors and controls
- Overload management (via external load cell)

SUPPLIED COMPONENTS

- Jands SP650AC-X motorised drum hoist
- User Manual
- Installation instructions and checklist

OPTIONAL ACCESSORIES

MODEL/PART	PART NUMBER
Single Axis Controller	JND-SAX-P1
Control Cabling Installation Kit.	JND-MP601
Acoustic mounting kit	JND-SP-AMK
In-Line head pulley with load cell	JND-HR230-W6LH
Rigging (loft) pulleys (230mm dia.)	JND-HR230xx

ARCHITECT & ENGINEER'S SPECIFICATION

Mechanical

The motorised hoist shall consist of a 266mm diameter grooved steel drum, designed to accommodate up to six (6) steel core or fibre core 6mm steel wire ropes of 20m length with dead and spare turns to AS1418.1-2002.

The grooved drum shall be fitted with machined and keyed drive shafts, welded to plates that are welded to shoulders bored into the ends of the grooved drum.

One shaft of the grooved drum shall be fitted to a solid steel machined bearing plate, with a sealed for life self aligning bearing. The other shaft of the grooved drum shall be fitted to the keyed hollow shaft output of a helical bevel gear reducer.

The gear reducer shall be fitted to a solid steel mounting plate of equal construction to the bearing plate. Both gear reducer plate and bearing plate shall be contained within a pair of profile cut steel plates of not less than 12mm thickness, cut to sufficiently close tolerance as to cause the drum, bearing and gearbox to self-align when fixing bolts are tightened, without the need for shims, packers or adjusting bolts.

Acoustic decoupling mounts shall be (optionally) provided to minimise mechanical transmission of noise.

The gear reducer service factor shall (fB_2) shall be sufficient to achieve a hoist classification of M5 using a utilisation class of not less than T_4 as defined in AS1418.1-2002.

A failsafe motor disc brake of sufficient size to arrest 125% of the hoist rated capacity at maximum speed without overheating shall be fitted.

A failsafe drum brake sized to the same torque requirements as the motor brake shall be fitted to the drum shaft.

The motorised hoist shall be designed, built and tested as a serial hoist in accordance to AS1418.2-1997. With the addition of an external load cell, the motorised hoist shall be able to meet the requirements of German safety regulation BGV-C1.

The motorised hoist shall be the Jands SP650AC-X

Electrical

The motorised hoist shall be powered by a 4.0kW, 4 pole AC asynchronous motor with a failsafe electromagnetically operated disc brake.

A discrete control enclosure, supplied with the hoist, shall connect to the motorised hoist via plugs and sockets and shall be fitted with a lockable "Drive Off" type control isolator.

This control enclosure shall contain an open loop electronic inverter drive with a capacity of not less than 4.0kW. Acceleration and deceleration times shall be ≥ 0.5 sec and ≤ 2 sec. Emergency Stop deceleration shall be 0.3sec.

An integral electronic control circuit shall manage safety inputs and encoder signals, shall monitor braking and emergency stop contactors, and shall directly control the electronic inverter direction and speed functions.

Regenerative braking resistors shall be sized to control the descent of the hoist under any condition of load or speed.

A 4 pole rotary limit switch, to AS60947.5.1-2004 shall be fitted directly coupled to the gearbox output shaft to provide both end-of-travel and over-travel limit functions.

The limit switch assembly shall be fitted with an incremental encoder of at least 1000ppr resolution to provide speed and position signals to the electronic control circuit.

An RJ45 socket on the hoist control enclosure shall be provided for the connection of a control pendant featuring 6 programmable position & speed presets, up and down controls, speed control, graphical displays of speed and position and an emergency stop pushbutton.

The motorised hoist shall be the Jands SP650AC-X.

