

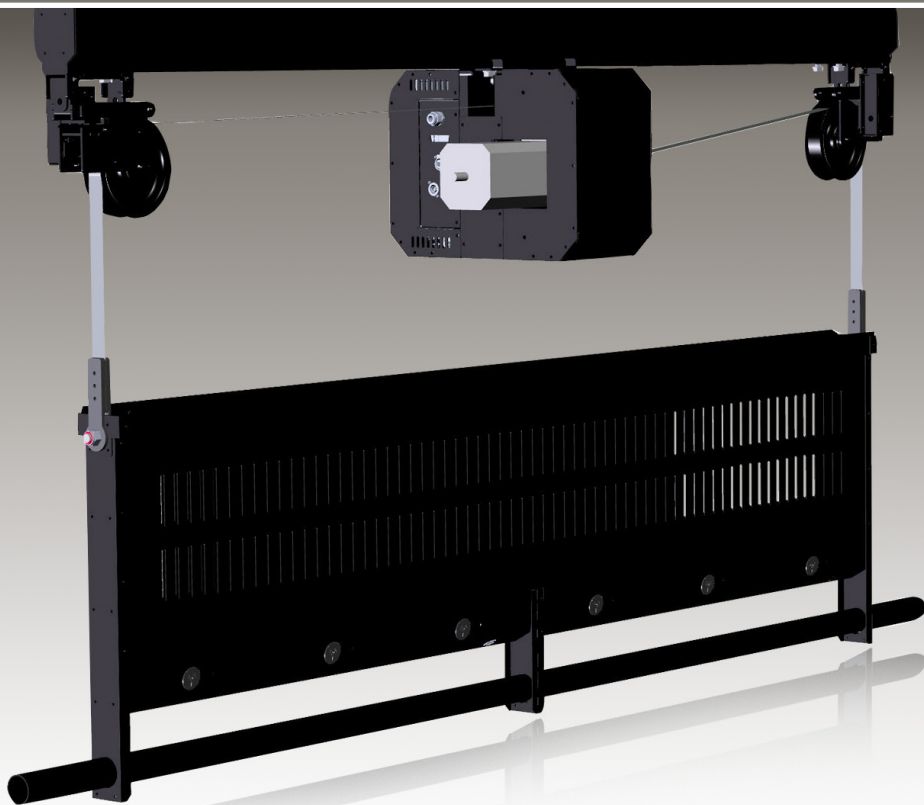

SLX-100

MOTORISED LIGHTING BATTEN



Jands SLX-100

The Jands SLX-100 Motorised Lighting Batten is an innovative packaged hoist for TV, dance and rehearsal studios, media venues, theatres, and other performance or corporate venues.

The SLX-100 Motorised Lighting Batten is based on the Jands SBH-150 Motorised Steel Band Hoist and the Jands JLX-PRO Lighting Bar.

An integrated energy chain cable management system reticulates cabling from the lighting bar. Cable trays fitted to the side of the motor unit facilitate the reticulation of cables past the hoist.

The dynamically irreversible gearbox and patented safety catch ensure that the highest levels of safety (German Safety Regulation BGV-C1) are achieved without the use of brakes.

This brakeless design ensures smooth acceleration and deceleration even under Emergency Stop and power failure conditions.

Overload and underload sensing is provided, and the gimbed design of the steel band pulleys minimises twisting of the bands.

The strut-style top channel of the SLX-100 Motorised Lighting Batten accepts the wide range of JLX-PRO accessories for fixing to wire ropes, chains and fixed supports.

Features

- Integrated cable management system.
- Steel band lifting system.
- Smooth silent operation.
- Dynamically irreversible gearbox and patented safety catch worm drive.
- BGV-C1 compliant design.
- Brakeless design for low maintenance.
- Utilises the wide range of JLX-PRO accessories.
- 8.0m lifting height.
- Working Load Limit (WLL) = 100kg.
- 0.2m/s (12m/min) lifting speed.
- 2.35m long batten.
- Tested to AS/NZS 3100:2002.
- 230/400V 50Hz, 6 x 10A circuits.

Overall Specifications

Lifting Speed :	0.2m/sec (12m/min)
Max Lifting Height :	8.0m
Motor :	0.55kW 4 Pole AC
Limit Switch :	4 pole rotary
Safety Standard :	BGV-C1
Overload/Underload :	Cut-out switch per band
Lifting Capacity :	100kg
Dimensions (mm) :	430(D) x 1400(H) x 23554(L)
Mass :	110kg
Power Supply :	230VAC 50Hz 6.8A
Motor Control :	Electric Inverter
Hoist Control :	SAX-P1 single axis controller (sold separately)

Ordering Information

MODEL/PART	PART NUMBER
Motorised Lighting Batten,100kg @ 8m drift & Controller	JND-SLX100
Motorised Batten Hoist,150kg @ 12m drift & Controller	JND-SBH150

